

Technical Information

Orbital Motors
Type CE



TABLE OF CONTENTS

TECHNICAL INFORMATION

Operating Recommendations4-5
 Motor Connections..... 5
 Product Testing (Understanding the Performance Charts)..... 6
 Allowable Bearing & Shaft Loads 7
 Vehicle Drive Calculations8-9
 Induced Side Loading 10
 Hydraulic Equations 10
 Shaft Nut Dimensions & Torque Specifications..... 11

OPTIONAL MOTOR FEATURES

Speed Sensor Options 12-13
 Freeturning Rotor Option 13
 Internal Drain 14
 Hydraulic Declutch..... 14
 Valve Cavity Option 15
 Slinger Seal Option..... 15

MEDIUM DUTY HYDRAULIC MOTORS

CE Product Line Introduction 16
 CE Displacement Performance Charts 17-22
 400 & 401 Series Housings 23
 400 & 401 Series Technical Information..... 24
 400 & 401 Series Shafts 24
 400 & 401 Series Ordering Information 25
 410 & 411 Series Housings 26
 410 & 411 Series Technical Information..... 27
 410 & 411 Series Shafts 27
 410 & 411 Series Ordering Information..... 28
 420 & 421 Series Housings 29
 420 & 421 Series Technical Information 30
 420 & 421 Series Shafts 30
 420 & 421 Series Ordering Information 31
 430 & 431 Series Housings..... 32
 430 & 431 Series Technical Information 33
 430 & 431 Series Shafts 33
 430 & 431 Series Ordering Information 34

OPERATING RECOMMENDATIONS

OIL TYPE

Hydraulic oils with anti-wear, anti-foam and demulsifiers are recommended for systems incorporating Impro Fluidtek motors. Straight oils can be used but may require VI (viscosity index) improvers depending on the operating temperature range of the system. Other water based and environmentally friendly oils may be used, but service life of the motor and other components in the system may be significantly shortened. Before using any type of fluid, consult the fluid requirements for all components in the system for compatibility. Testing under actual operating conditions is the only way to determine if acceptable service life will be achieved.

FLUID VISCOSITY & FILTRATION

Fluids with a viscosity between 20 - 43 cSt [100 - 200 S.U.S.] at operating temperature is recommended. Fluid temperature should also be maintained below 85°C [180° F]. It is also suggested that the type of pump and its operating specifications be taken into account when choosing a fluid for the system. Fluids with high viscosity can cause cavitation at the inlet side of the pump. Systems that operate over a wide range of temperatures may require viscosity improvers to provide acceptable fluid performance.

Impro Fluidtek recommends maintaining an oil cleanliness level of ISO 17-14 or better.

INSTALLATION & START-UP

When installing an Impro Fluidtek motor it is important that the mounting flange of the motor makes full contact with the mounting surface of the application. Mounting hardware of the appropriate grade and size must be used. Hubs, pulleys, sprockets and couplings must be properly aligned to avoid inducing excessive thrust or radial loads. Although the output device must fit the shaft snug, a hammer should never be used to install any type of output device onto the shaft. The port plugs should only be removed from the motor when the system connections are ready to be made. To avoid contamination, remove all matter from around the ports of the motor and the threads of the fittings. Once all system connections are made, it is recommended that the motor be run-in for 15-30 minutes at no load and half speed to remove air from the hydraulic system.

MOTOR PROTECTION

Over-pressurization of a motor is one of the primary causes of motor failure. To prevent these situations, it is necessary to provide adequate relief protection for a motor based on the pressure ratings for that particular model. For systems that may experience overrunning conditions, special precautions must be taken. In an overrunning condition, the motor functions as a pump and attempts to convert kinetic energy into hydraulic energy. Unless the system is properly

configured for this condition, damage to the motor or system can occur. To protect against this condition a counterbalance valve or relief cartridge must be incorporated into the circuit to reduce the risk of over-pressurization. If a relief cartridge is used, it must be installed upline of the motor, if not in the motor, to relieve the pressure created by the over-running motor. To provide proper motor protection for an over-running load application, the pressure setting of the pressure relief valve must not exceed the intermittent rating of the motor.

HYDRAULIC MOTOR SAFETY PRECAUTION

A hydraulic motor must not be used to hold a suspended load. Due to the necessary internal tolerances, all hydraulic motors will experience some degree of creep when a load induced torque is applied to a motor at rest. All applications that require a load to be held must use some form of mechanical brake designed for that purpose.

MOTOR/BRAKE PRECAUTION

Caution! - Impro Fluidtek motor/brakes are intended to operate as static or parking brakes. System circuitry must be designed to bring the load to a stop before applying the brake.

Caution! - Because it is possible for some large displacement motors to overpower the brake, it is critical that the maximum system pressure be limited for these applications. Failure to do so could cause serious injury or death. When choosing a motor/brake for an application, consult the performance chart for the series and displacement chosen for the application to verify that the maximum operating pressure of the system will not allow the motor to produce more torque than the maximum rating of the brake. Also, it is vital that the system relief be set low enough to insure that the motor is not able to overpower the brake.

To ensure proper operation of the brake, a separate case drain back to tank must be used. Use of the internal drain option is not recommended due to the possibility of return line pressure spikes. A simple schematic of a system utilizing a motor/brake is shown on page 5. Although maximum brake release pressure may be used for an application, a 34 bar [500 psi] pressure reducing valve is recommended to promote maximum life for the brake release piston seals. However, if a pressure reducing valve is used in a system which has case drain back pressure, the pressure reducing valve should be set to 34 bar [500 psi] over the expected case pressure to ensure full brake release. To achieve proper brake release operation, it is necessary to bleed out any trapped air and fill brake release cavity and hoses before all connections are tightened. To facilitate this operation, all motor/brakes feature two release ports. One or both of these ports may be used to release the brake in the

OPERATING RECOMMENDATIONS & MOTOR CONNECTIONS

MOTOR/BRAKE PRECAUTION (continued)

unit. Motor/brakes should be configured so that the release ports are near the top of the unit in the installed position.

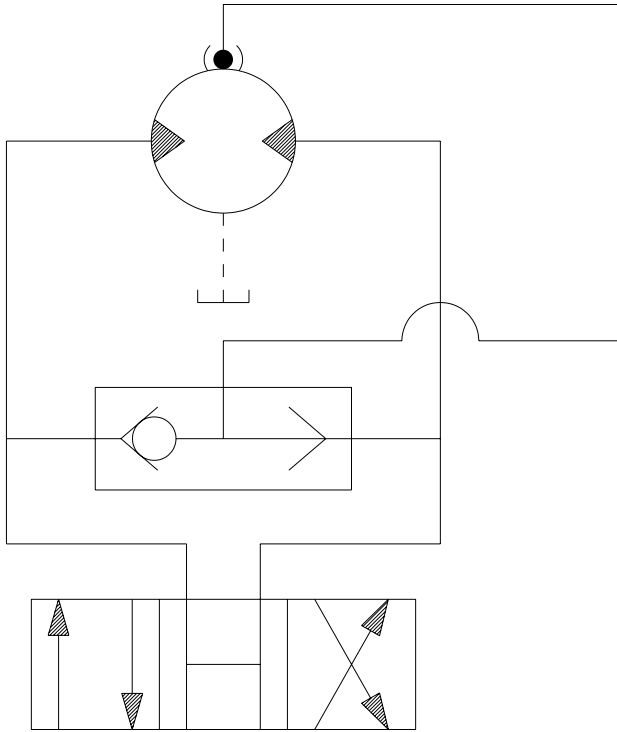

TYPICAL MOTOR/BRAKE SCHEMATIC

Once all system connections are made, one release port must be opened to atmosphere and the brake release line carefully charged with fluid until all air is removed from the line and motor/brake release cavity. When this has been accomplished the port plug or secondary release line must be reinstalled. In the event of a pump or battery failure, an external pressure source may be connected to the brake release port to release the brake, allowing the machine to be moved.

► NOTE: It is vital that all operating recommendations be followed. Failure to do so could result in injury or death.

MOTOR CIRCUITS

There are two common types of circuits used for connecting multiple numbers of motors – series connection and parallel connection.

SERIES CONNECTION

When motors are connected in series, the outlet of one motor is connected to the inlet of the next motor. This allows the full pump flow to go through each motor and provide maximum speed. Pressure and torque are distributed between the motors based on the load each motor is subjected to. The maximum system pressure must be no greater than the maximum inlet pressure of the first motor. The allowable back pressure rating for a motor must also be considered. In some series circuits the motors must have an external case drain connected. A series connection is desirable when it is important for all the motors to run the same speed such as on a long line conveyor.

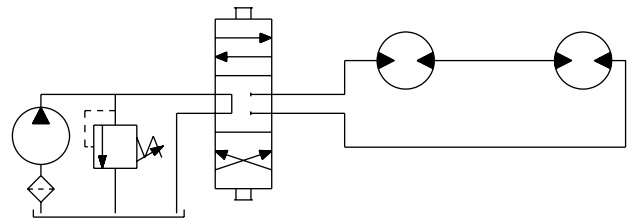

SERIES CIRCUIT

PARALLEL CONNECTION

In a parallel connection all of the motor inlets are connected. This makes the maximum system pressure available to each motor allowing each motor to produce full torque at that pressure. The pump flow is split between the individual motors according to their loads and displacements. If one motor has no load, the oil will take the path of least resistance and all the flow will go to that one motor. The others will not turn. If this condition can occur, a flow divider is recommended to distribute the oil and act as a differential.

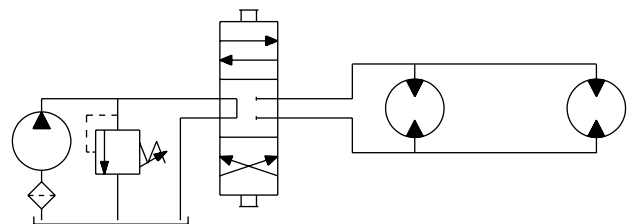

PARALLEL CIRCUIT

► NOTE: The motor circuits shown above are for illustration purposes only. Components and circuitry for actual applications may vary greatly and should be chosen based on the application.

PRODUCT TESTING

Performance testing is the critical measure of a motor's ability to convert flow and pressure into speed and torque. All product testing is conducted using an Impro Fluidtek state of the art test facility. This facility utilizes fully automated test equipment and custom designed software to provide accurate, reliable test data. Test routines are standardized, including test stand calibration and stabilization of fluid temperature and viscosity, to provide consistent data. The example below provides an explanation of the values pertaining to each heading on the performance chart.

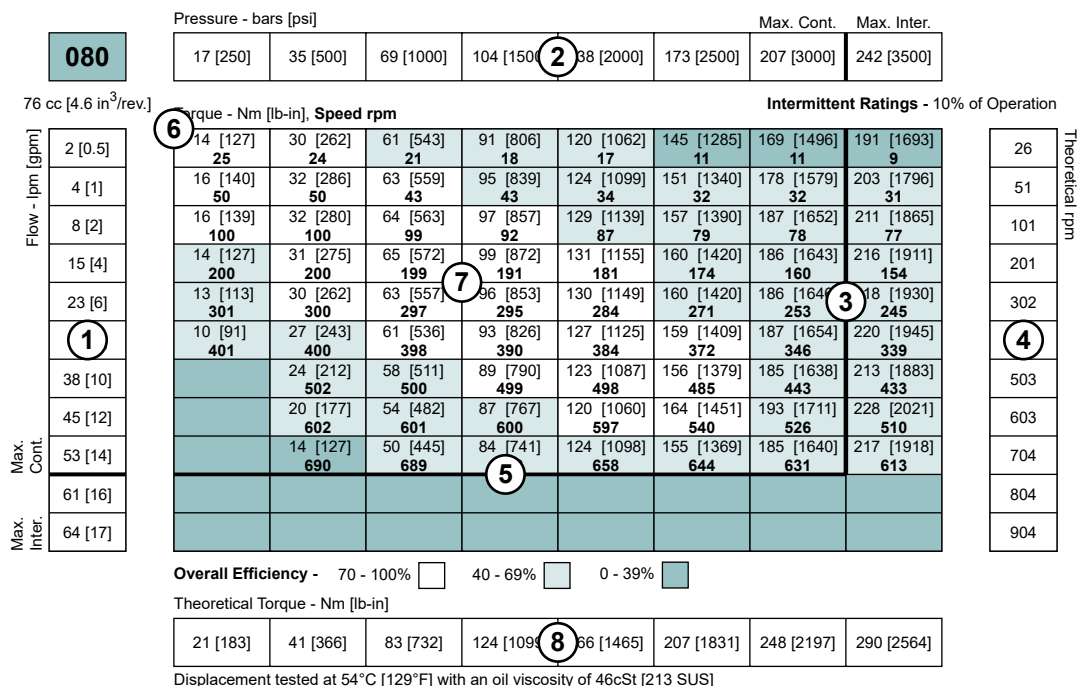

- Flow represents the amount of fluid passing through the motor during each minute of the test.
- Pressure refers to the measured pressure differential between the inlet and return ports of the motor during the test.
- The maximum continuous pressure rating and maximum intermittent pressure rating of the motor are separated by the dark lines on the chart.
- Theoretical RPM represents the RPM that the motor would produce if it were 100% volumetrically efficient. Measured RPM divided by the theoretical RPM give the actual volumetric efficiency of the motor.
- The maximum continuous flow rating and maximum intermittent flow rating of the motor are separated by the dark line on the chart.
- Performance numbers represent the actual torque and speed generated by the motor based on the corresponding input pressure and flow. The numbers on the top row indicate torque as measured in Nm [lb-in], while the bottom number represents the speed of the output shaft.
- Areas within the white shading represent maximum motor efficiencies.
- Theoretical Torque represents the torque that the motor would produce if it were 100% mechanically efficient. Actual torque divided by the theoretical torque gives the actual mechanical efficiency of the motor.

ALLOWABLE BEARING & SHAFT LOADING

This catalog provides curves showing allowable radial loads at points along the longitudinal axis of the motor. They are dimensioned from the mounting flange. Two capacity curves for the shaft and bearings are shown. A vertical line through the centerline of the load drawn to intersect the x-axis intersects the curves at the load capacity of the shaft and of the bearing.

In the example below the maximum radial load bearing rating is between the internal roller bearings illustrated with a solid line. The allowable shaft rating is shown with a dotted line.

The bearing curves for each model are based on laboratory analysis and testing results constructed at Impro Fluidtek. The shaft loading is based on a 3:1 safety factor and 330 Kpsi tensile strength. The allowable load is the lower of the curves at a given point. For instance, one inch in front of the mounting flange the bearing capacity is lower than the shaft capacity. In this case, the bearing is the limiting load. The motor user needs to determine which series of motor to use based on their application knowledge.

ISO 281 RATINGS VS. MANUFACTURERS RATINGS

Published bearing curves can come from more than one type of analysis. The ISO 281 bearing rating is an international standard for the dynamic load rating of roller bearings. The rating is for a set load at a speed of 33 1/3 RPM for 500 hours (1 million revolutions). The standard was established to allow consistent comparisons of similar bearings between manufacturers. The ISO 281 bearing ratings are based solely on the physical characteristics of the bearings, removing any manufacturers specific safety factors or empirical data that influences the ratings.

Manufacturers' ratings are adjusted by diverse and systematic laboratory investigations, checked constantly with feedback from practical experience. Factors taken into account that affect bearing life are material, lubrication, cleanliness of the lubrication, speed, temperature, magnitude of the load and the bearing type.

The operating life of a bearing is the actual life achieved by the bearing and can be significantly different from the calculated life. Comparison with similar applications is the most accurate method for bearing life estimations.

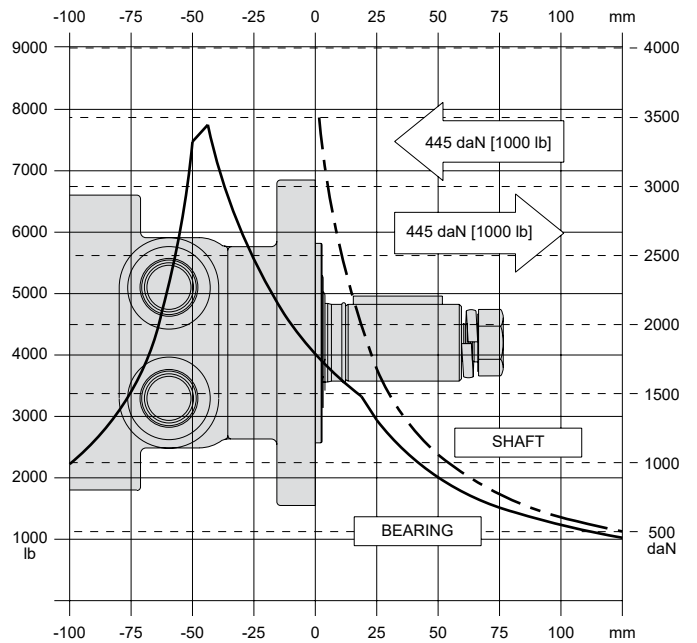

EXAMPLE LOAD RATING FOR MECHANICALLY RETAINED NEEDLE ROLLER BEARINGS

- Bearing Life L_{10} = $(C/P)^p [10^6 \text{ revolutions}]$
- L_{10} = nominal rating life
- C = dynamic load rating
- P = equivalent dynamic load
- Life Exponent p = 10/3 for needle bearings

BEARING LOAD MULTIPLICATION FACTOR TABLE			
RPM	FACTOR	RPM	FACTOR
50	1.23	500	0.62
100	1.00	600	0.58
200	0.81	700	0.56
300	0.72	800	0.50
400	0.66		

VEHICLE DRIVE CALCULATIONS

When selecting a wheel drive motor for a mobile vehicle, a number of factors concerning the vehicle must be taken into consideration to determine the required maximum motor RPM, the maximum torque required and the maximum load each motor must support. The following sections contain the necessary equations to determine this criteria. An example is provided to illustrate the process.

Sample application (vehicle design criteria)

vehicle description 4 wheel vehicle
 vehicle drive 2 wheel drive
 GVW 1,500 lbs.
 weight over each drive wheel 425 lbs.
 rolling radius of tires 16 in.
 desired acceleration 0-5 mph in 10 sec.
 top speed 5 mph
 gradability 20%
 worst working surface poor asphalt

To determine maximum motor speed

$$\text{RPM} = \frac{2.65 \times \text{KPH} \times G}{r_m} \qquad \text{RPM} = \frac{168 \times \text{MPH} \times G}{r_i}$$

Where:

MPH = max. vehicle speed (miles/hr)
 KPH = max. vehicle speed (kilometers/hr)
 r_i = rolling radius of tire (inches)
 G = gear reduction ratio (if none, G = 1)
 r_m = rolling radius of tire (meters)

Example $\text{RPM} = \frac{168 \times 5 \times 1}{16} = 52.5$

To determine maximum torque requirement of motor

To choose a motor(s) capable of producing enough torque to propel the vehicle, it is necessary to determine the Total Tractive Effort (TE) requirement for the vehicle. To determine the total tractive effort, the following equation must be used:

$$\text{TE} = \text{RR} + \text{GR} + \text{FA} + \text{DP} \text{ (lbs or N)}$$

Where:

TE = Total tractive effort
 RR = Force necessary to overcome rolling resistance
 GR = Force required to climb a grade
 FA = Force required to accelerate
 DP = Drawbar pull required

The components for this equation may be determined using the following steps:

Step One: Determine Rolling Resistance

Rolling Resistance (RR) is the force necessary to propel a vehicle over a particular surface. It is recommended that the worst possible surface type to be encountered by the vehicle be factored into the equation.

$$\text{RR} = \frac{\text{GVW}}{1000} \times R \text{ (lb or N)}$$

Where:

GVW = gross (loaded) vehicle weight (lb or kg)
 R = surface friction (value from Table 1)

Example $\text{RR} = \frac{1500}{1000} \times 22 \text{ lbs} = 33 \text{ lbs}$

Table 1

Rolling Resistance	
Concrete (excellent).....	10
Concrete (good).....	15
Concrete (poor).....	20
Asphalt (good).....	12
Asphalt (fair).....	17
Asphalt (poor).....	22
Macadam (good).....	15
Macadam (fair).....	22
Macadam (poor).....	37
Cobbles (ordinary).....	55
Cobbles (poor).....	37
Snow (2 inch).....	25
Snow (4 inch).....	37
Dirt (smooth).....	25
Dirt (sandy).....	37
Mud.....	37 to 150
Sand (soft).....	60 to 150
Sand (dune).....	160 to 300

Step Two: Determine Grade Resistance

Grade Resistance (GR) is the amount of force necessary to move a vehicle up a hill or "grade." This calculation must be made using the maximum grade the vehicle will be expected to climb in normal operation.

To convert incline degrees to % Grade:

$$\% \text{ Grade} = [\tan \text{ of angle (degrees)}] \times 100$$

$$\text{GR} = \frac{\% \text{ Grade}}{100} \times \text{GVW} \text{ (lb or N)}$$

Example $\text{GR} = \frac{20}{100} \times 1500 \text{ lbs} = 300 \text{ lbs}$

VEHICLE DRIVE CALCULATIONS

Step Three: Determine Acceleration Force

Acceleration Force (FA) is the force necessary to accelerate from a stop to maximum speed in a desired time.

$$FA = \frac{MPH \times GVW \text{ (lb)}}{22 \times t} \qquad FA = \frac{KPH \times GVW \text{ (N)}}{35.32 \times t}$$

Where:

t = time to maximum speed (seconds)

Example $FA = \frac{5 \times 1500 \text{ lbs}}{22 \times 10} = 34 \text{ lbs}$

Step Four: Determine Drawbar Pull

Drawbar Pull (DP) is the additional force, if any, the vehicle will be required to generate if it is to be used to tow other equipment. If additional towing capacity is required for the equipment, repeat steps one through three for the towable equipment and sum the totals to determine DP.

Step Five: Determine Total Tractive Effort

The Tractive Effort (TE) is the sum of the forces calculated in steps one through three above. On low speed vehicles, wind resistance can typically be neglected. However, friction in drive components may warrant the addition of 10% to the total tractive effort to insure acceptable vehicle performance.

$$TE = RR + GR + FA + DP \text{ (lb or N)}$$

Example $TE = 33 + 300 + 34 + 0 \text{ (lbs)} = 367 \text{ lbs}$

Step Six: Determine Motor Torque

The Motor Torque (T) required per motor is the Total Tractive Effort divided by the number of motors used on the machine. Gear reduction is also factored into account in this equation.

$$T = \frac{TE \times r_i}{M \times G} \text{ lb-in per motor} \qquad T = \frac{TE \times r_m}{M \times G} \text{ Nm per motor}$$

Where:

M = number of driving motors

Example $T = \frac{367 \times 16}{2 \times 1} \text{ lb-in/motor} = 2936 \text{ lb-in}$

Step Seven: Determine Wheel Slip

To verify that the vehicle will perform as designed in regards to tractive effort and acceleration, it is necessary to calculate wheel slip (TS) for the vehicle. In special cases, wheel slip may actually be desirable to prevent hydraulic system overheating and component breakage should the vehicle become stalled.

$$TS = \frac{W \times f \times r_i}{G} \qquad TS = \frac{W \times f \times r_m}{G}$$

(lb-in per motor) (N-m per motor)

Where:

f = coefficient of friction (see table 2)

W = loaded vehicle weight over driven wheel (lb or N)

Example $TS = \frac{425 \times .06 \times 16}{1} \text{ lb-in/motor} = 4080 \text{ lbs}$

Table 2

Coefficient of friction (f)	
Steel on steel.....	0.3
Rubber tire on dirt.....	0.5
Rubber tire on a hard surface.....	0.6 - 0.8
Rubber tire on cement.....	0.7

To determine radial load capacity requirement of motor

When a motor used to drive a vehicle has the wheel or hub attached directly to the motor shaft, it is critical that the radial load capabilities of the motor are sufficient to support the vehicle. After calculating the Total Radial Load (RL) acting on the motors, the result must be compared to the bearing/shaft load charts for the chosen motor to determine if the motor will provide acceptable load capacity and life.

$$RL = \sqrt{W^2 + \left(\frac{T}{r_i}\right)^2} \text{ lb} \qquad RL = \sqrt{W^2 + \left(\frac{T}{r_m}\right)^2} \text{ kg}$$

Example $RL = \sqrt{425^2 + \left(\frac{2936}{16}\right)^2} = 463 \text{ lbs}$

Once the maximum motor RPM, maximum torque requirement, and the maximum load each motor must support have been determined, these figures may then be compared to the motor performance charts and to the bearing load curves to choose a series and displacement to fulfill the motor requirements for the application.

INDUCED SIDE LOAD

In many cases, pulleys or sprockets may be used to transmit the torque produced by the motor. Use of these components will create a torque induced side load on the motor shaft and bearings. It is important that this load be taken into consideration when choosing a motor with sufficient bearing and shaft capacity for the application.

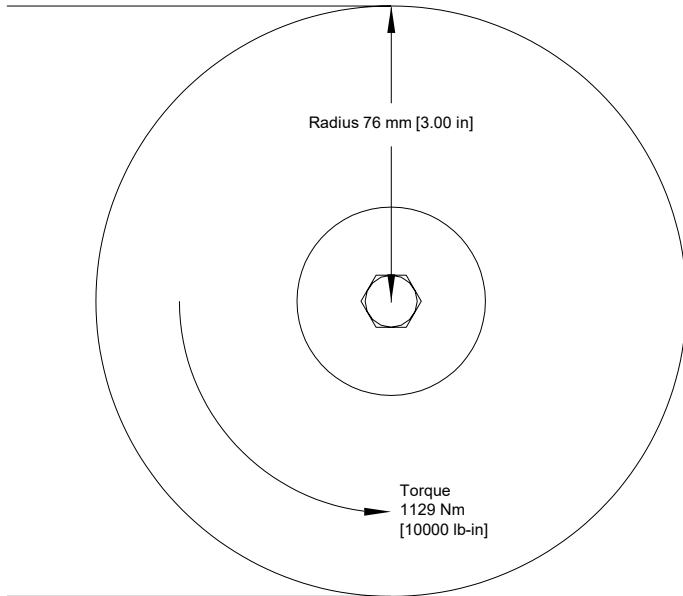

To determine the side load, the motor torque and pulley or sprocket radius must be known. Side load may be calculated using the formula below. The distance from the pulley/sprocket centerline to the mounting flange of the motor must also be determined. These two figures may then be compared to the bearing and shaft load curve of the desired motor to determine if the side load falls within acceptable load ranges.

$$\text{Side Load} = \frac{\text{Torque}}{\text{Radius}}$$

$$\text{Side Load} = 14855 \text{ N [3333 lbs]}$$

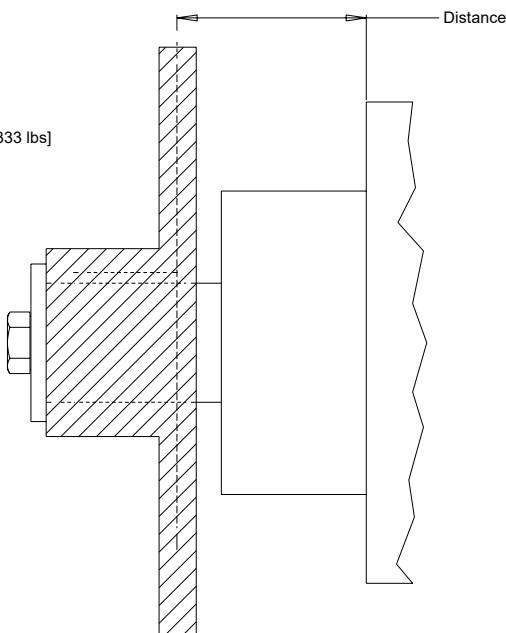

HYDRAULIC EQUATIONS

Multiplication Factor	Abbrev.	Prefix
10 ¹²	T	tera
10 ⁹	G	giga
10 ⁶	M	mega
10 ³	K	kilo
10 ²	h	hecto
10 ¹	da	deka
10 ⁻¹	d	deci
10 ⁻²	c	centi
10 ⁻³	m	milli
10 ⁻⁶	u	micro
10 ⁻⁹	n	nano
10 ⁻¹²	p	pico
10 ⁻¹⁵	f	femto
10 ⁻¹⁸	a	atto

Theo. Speed (RPM) =

$$\frac{1000 \times \text{LPM}}{\text{Displacement (cm}^3\text{/rev)}} \quad \text{or} \quad \frac{231 \times \text{GPM}}{\text{Displacement (in}^3\text{/rev)}}$$

Theo. Torque (lb-in) =

$$\frac{\text{Bar} \times \text{Disp. (cm}^3\text{/rev)}}{20 \pi} \quad \text{or} \quad \frac{\text{PSI} \times \text{Displacement (in}^3\text{/rev)}}{6.28}$$

Power In (HP) =

$$\frac{\text{Bar} \times \text{LPM}}{600} \quad \text{or} \quad \frac{\text{PSI} \times \text{GPM}}{1714}$$

Power Out (HP) =

$$\frac{\text{Torque (Nm)} \times \text{RPM}}{9543} \quad \text{or} \quad \frac{\text{Torque (lb-in)} \times \text{RPM}}{63024}$$

SHAFT NUT INFORMATION

35MM TAPERED SHAFTS
M24 x 1.5 Thread

A Slotted Nut

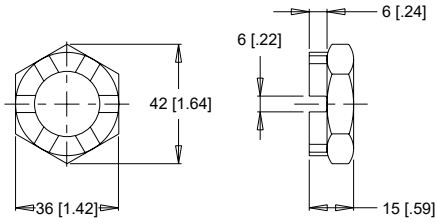

Torque Specifications: 32.5 daNm [240 ft.lb.]

PRECAUTION

The tightening torques listed with each nut should only be used as a guideline. Hubs may require higher or lower tightening torque depending on the material. Consult the hub manufacturer to obtain recommended tightening torque. To maximize torque transfer from the shaft to the hub, and to minimize the potential for shaft breakage, a hub with sufficient thickness must fully engage the taper length of the shaft.

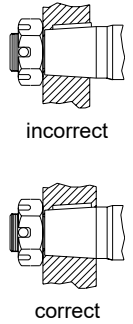

1" TAPERED SHAFTS
3/4-28 Thread

A Slotted Nut

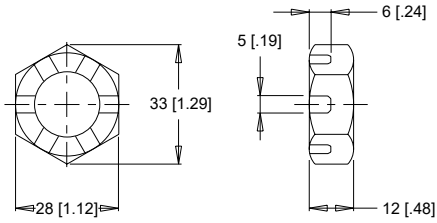

Torque Specifications: 20 - 23 daNm [150 - 170 ft.lb.]

B Lock Nut

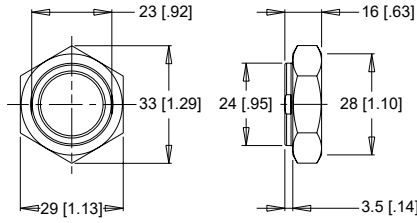

Torque Specifications: 24 - 27 daNm [180 - 200 ft.lb.]

C Solid Nut

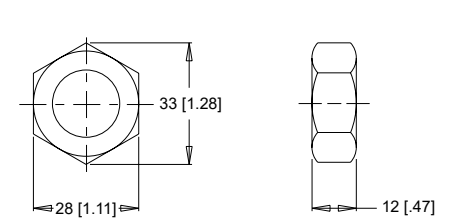

Torque Specifications: 20 - 23 daNm [150 - 170 ft.lb.]

1-1/4" TAPERED SHAFTS
1-20 Thread

A Slotted Nut

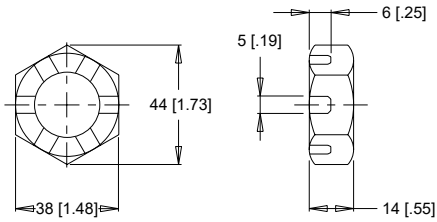

Torque Specifications: 38 daNm [280 ft.lb.] Max.

B Lock Nut

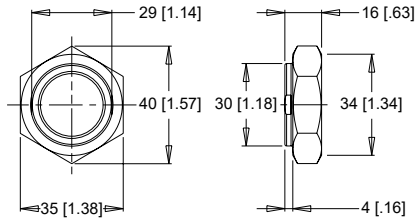

Torque Specifications: 33 - 42 daNm [240 - 310 ft.lb.]

C Solid Nut

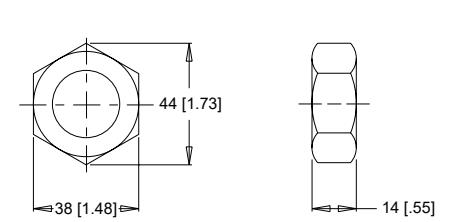

Torque Specifications: 38 daNm [280 ft.lb.] Max.

1-3/8" & 1-1/2" TAPERED SHAFTS
1 1/8-18 Thread

A Slotted Nut

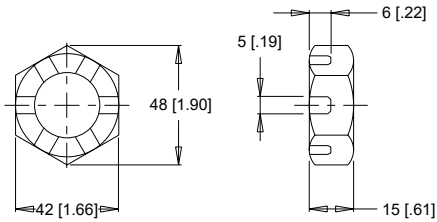

Torque Specifications: 41 - 54 daNm [300 - 400 ft.lb.]

B Lock Nut

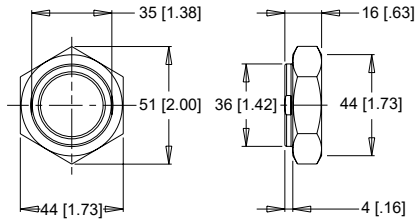

Torque Specifications: 34 - 48 daNm [250 - 350 ft.lb.]

C Solid Nut

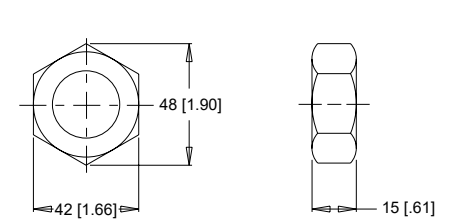

Torque Specifications: 41 - 54 daNm [300 - 400 ft.lb.]

SPEED SENSORS

Impro Fluidtek offers both single and dual element speed sensor options providing a number of benefits to users by incorporating the latest advancements in sensing technology and materials. The single element sensors provide 50 pulses per revolution with the dual element providing 100 pulses per revolution.” Higher resolution is especially beneficial for slow speed applications, where more information is needed for smooth and accurate control. The dual sensor option also provides a direction signal allowing end-users to monitor the direction of shaft rotation.

Unlike competitive designs that breach the high pressure area of the motor to add the sensor, the Impro Fluidtek speed sensor option utilizes an add-on flange to locate all sensor components outside the high pressure operating environment. This eliminates the potential leak point common to competitive designs. Many improvements were made to the sensor flange including changing the material from cast iron to acetal resin, incorporating a Buna-N shaft seal internal to the flange, and providing a grease zerk, which allows the user to fill the sensor cavity with grease. These improvements enable the flange to withstand the rigors of harsh environments.

Another important feature of the new sensor flange is that it is self-centering, which allows it to remain concentric to the magnet rotor. This produces a consistent mounting location for the new sensor module, eliminating the need to adjust

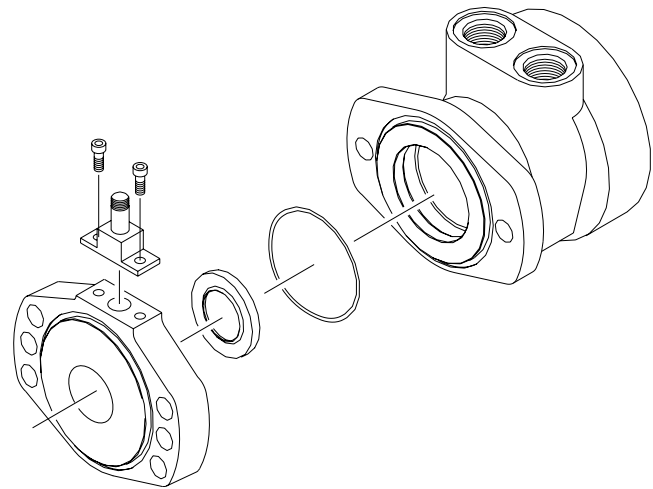

the air gap between the sensor and magnet rotor. The o-ring sealed sensor module attaches to the sensor flange with two small screws, allowing the sensor to be serviced or upgraded in the field in under one minute. This feature is especially valuable for mobile applications where machine downtime is costly. The sensor may also be serviced without exposing the hydraulic circuit to the atmosphere. Another advantage of the self-centering flange is that it allows users to rotate the sensor to a location best suited to their application. This feature is not available on competitive designs, which fix the sensor in one location in relationship to the motor mounting flange.

FEATURES / BENEFITS

- Grease fitting allows sensor cavity to be filled with grease for additional protection.
- Internal extruder seal protects against environmental elements.
- M12 or weatherpack connectors provide installation flexibility.
- Dual element sensor provides up to 100 pulses per revolution and directional sensing.
- Modular sensor allows quick and easy servicing.
- Acetal resin flange is resistant to moisture, chemicals, oils, solvents and greases.
- Self-centering design eliminates need to set magnet-to-sensor air gap.
- Protection circuitry

SENSOR OPTIONS

Z - 4-pin M12 male connector

This option has 50 pulses per revolution on all series. This option will not detect direction.

Y - 3-pin male weatherpack connector*

This option has 50 pulses per revolution on all series. This option will not detect direction.

X - 4-pin M12 male connector

This option has 100 pulses per revolution on all series. This option will detect direction.

W - 4-pin male weatherpack connector*

This option has 100 pulses per revolution on all series. This option will detect direction.

*These options include a 610mm [2 ft] cable.

SPEED SENSORS

SINGLE ELEMENT SENSOR - Y & Z

Supply voltages 7.5-24 Vdc
 Maximum output off voltage 24V
 Maximum continuous output current < 25 ma
 Signal levels (low, high) 0.8 to supply voltage
 Operating Temp -30°C to 83°C [-22°F to 181°F]

DUAL ELEMENT SENSOR - X & W

Supply voltages 7.5-18 Vdc
 Maximum output off voltage 18V
 Maximum continuous output current < 20 ma
 Signal levels (low, high) 0.8 to supply voltage
 Operating Temp -30°C to 83°C [-22°F to 181°F]

SENSOR CONNECTORS

Z Option

PIN

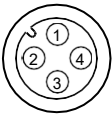

1	positive	brown or red
2	n/a	white
3	negative	blue
4	pulse out	black

X Option

PIN

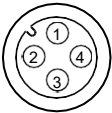

1	positive	brown or red
2	direction out	white
3	negative	blue
4	pulse out	black

Y Option

PIN

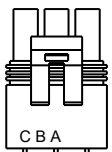

A	positive	brown or red
B	negative	blue
C	pulse out	black
D	n/a	white

W Option

PIN

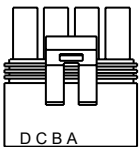

A	positive	brown or red
B	negative	blue
C	pulse out	black
D	direction out	white

PROTECTION CIRCUITRY

The single element sensor has been improved and incorporates protection circuitry to avoid electrical damage caused by:

- reverse battery protection
- overvoltage due to power supply spikes and surges (60 Vdc max.)
- power applied to the output lead

The protection circuit feature will help “save” the sensor from damage mentioned above caused by:

- faulty installation wiring or system repair
- wiring harness shorts/opens due to equipment failure or harness damage resulting from accidental conditions (i.e. severed or grounded wire, ice, etc.)
- power supply spikes and surges caused by other electrical/electronic components that may be intermittent or damaged and “loading down” the system.

While no protection circuit can guarantee against any and all fault conditions. The single element sensor from Impro Fluidtek with protection circuitry is designed to handle potential hazards commonly seen in real world applications.

Unprotected versions are also available for operation at lower voltages down to 4.5V.

FREE TURNING ROTOR

The ‘AC’ option or “Free turning” option refers to a specially prepared rotor assembly. This rotor assembly has increased clearance between the rotor tips and rollers allowing it to turn more freely than a standard rotor assembly. For spool valve motors, additional clearance is also provided between the shaft and housing bore. The ‘AC’ option is available for all motor series and displacements.

There are several applications and duty cycle conditions where ‘AC’ option performance characteristics can be beneficial. In continuous duty applications that require high flow/high rpm operation, the benefits are twofold. The additional clearance helps to minimize internal pressure drop at high flows. This clearance also provides a thicker oil film at metal to metal contact areas and can help extend the life of the motor in high rpm or even over speed conditions. The ‘AC’ option should be considered for applications that require continuous operation above 57 LPM [15 GPM] and/or 300 rpm. Applications that are subject to pressure spikes due to frequent reversals or shock loads can also benefit by specifying the ‘AC’ option. The additional clearance serves to act as a buffer against spikes, allowing them to be bypassed through the motor rather than being absorbed and transmitted through the drive link to the output shaft. The trade-off for achieving these benefits is a slight loss of volumetric efficiency at high pressures.

INTERNAL DRAIN

The internal drain is standard on all WD, WP, WR, and WS360. Typically, a separate drain line must be installed to direct case leakage of the motor back to the reservoir when using, WS365/366. However, the internal drain option eliminates the need for a separate drain line through the installation of two check valves in the motor. This simplifies plumbing requirements for the motor.

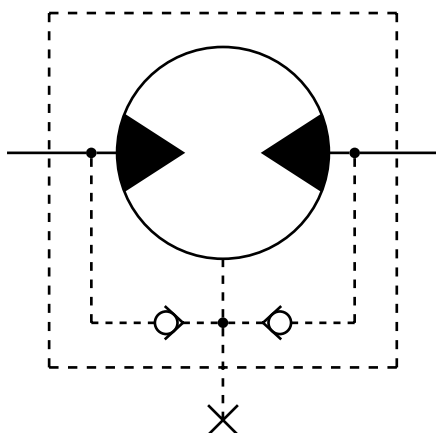

The two check valves connect the case area of the motor to each port of the endcover. During normal motor operation, pressure in the input and return lines of the motor close the check valves. However, when the pressure in the case of the motor is greater than that of the return line, the check valve between the case and low pressure line opens, allowing the case leakage to flow into the return line. Since the operation of the check valves is dependent upon a pressure differential, the internal drain option operates in either direction of motor rotation.

Although this option can simplify many motor installations, precautions must be taken to insure that return line pressure remains below allowable levels (see table below) to insure proper motor operation and life. If return line pressure is higher than allowable, or experiences pressure spikes, this pressure may feed back into the motor, possibly causing catastrophic seal failure. Installing motors with internal drains in series is not recommended unless overall pressure drop over all motors is below the maximum allowable backpressure as listed in the chart below. If in doubt, contact your authorized Impro Fluidtek representative.

MAXIMUM ALLOWABLE BACK PRESSURE		
Series	Cont. bar [psi]	Inter. bar [psi]
Brakes	34 [500]	34 [500]

HYDRAULIC DECLUTCH

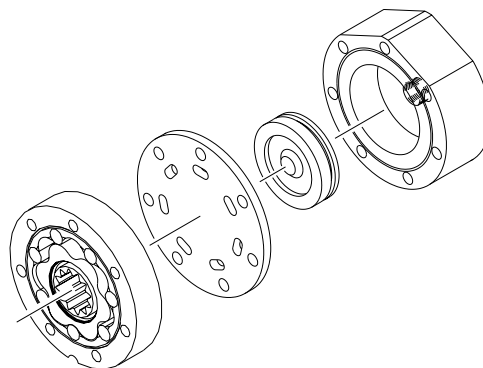

The declutch or 'AE' option, available on the RE and CE Series motors, has been specifically designed for applications requiring the motor to have the ability to "freewheel" when not pressurized. By making minor changes to internal components, the torque required to turn the output shaft is minimal. Selection of this option allows freewheeling speeds up to 1,000 RPM* depending on the displacement of the motor and duty cycle of the application.

To enable the motor to perform this function, the standard rotor assembly is replaced with a freeturn rotor assembly. Next, the standard balance plate and endcover is replaced with a special wear plate and ported endcover. The wear plate features seven holes that connect the stator pockets to each other. The ported endcover features a movable piston capable of sealing the seven holes in the wear plate.

When standard motor function is required, pressure is supplied to the endcover port, moving the piston against the wear plate. This action seals the seven holes allowing the motor to function as normal. However, when pressure is removed from the endcover port, the pressure created by the turning rotor assembly pushes the piston away from the wear plate, opening the rotor pockets to each other. In this condition, oil may circulate freely within the rotor and endcover assemblies, allowing the rotor assembly to rotate freely within the motor.

This option is especially useful in applications ranging from winch drives to towable wheel drives. Depending on the valves and hydraulic circuitry, operation of the freewheel function may be manually or automatically selected. A basic schematic is shown to the right.

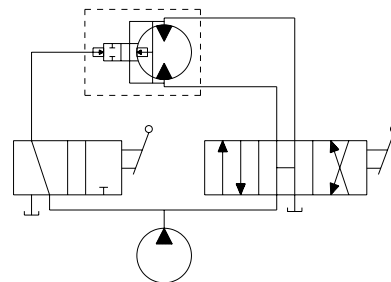

► The 1,000 RPM rating was based on smaller displacement options with forced flow flushing through the motor to provide cooling.

VALVE CAVITY

The valve cavity option provides a cost effective way to incorporate a variety of cartridge valves integral to the motor. The valve cavity is a standard 10 series 2-way cavity that accepts numerous cartridge valves, including over-running check valves, relief cartridges, flow control valves, pilot operated check fuses, and high pressure shuttle valves. Installation of a relief cartridge into the cavity provides an extra margin of safety for applications encountering frequent pressure spikes. Relief cartridges from 69 to 207 bar [1000 to 3000 psi] may also be factory installed.

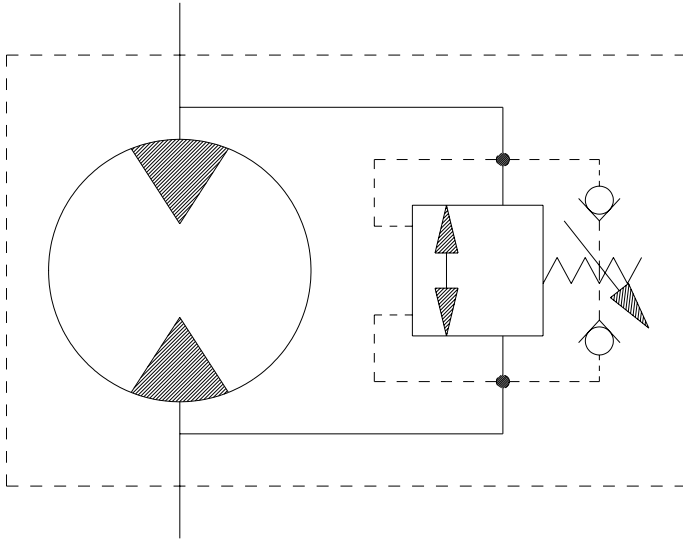

For basic systems with fixed displacement pumps, either manual or motorized flow control valves may be installed into the valve cavity to provide a simple method for controlling motor speed. It is also possible to incorporate the speed sensor option and a programmable logic controller with a motorized flow control valve to create a closed loop, fully automated speed control system. For motors with internal brakes, a shuttle valve cartridge may be installed into the cavity to provide a simple, fully integrated method for supplying release pressure to the pilot line to actuate an integral brake. To discuss other alternatives for the valve cavity option, contact an authorized Impro Fluidtek distributor.

SLINGER SEAL

Slinger seals are available on select series offered by Impro Fluidtek. Slinger seals offer extended shaft/shaft seal protection by prevented a buildup of material around the circumference of the shaft which can lead to premature shaft seal failures. The Impro Fluidtek slinger seals are designed to be larger in diameter than competitive products, providing greater surface speed and 'slinging action'.

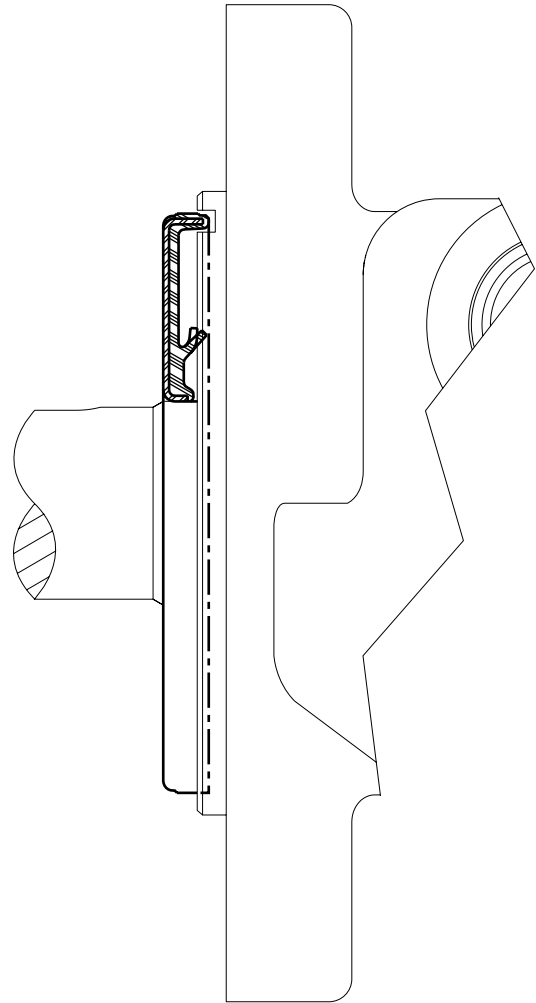

Slinger seals are also available on 4-hole flange mounts on select series. Contact a Impro Fluidtek Customer Service Representative for additional information.

OVERVIEW

The combination of compact size, light weight and low speed efficiency make the CE motor the best wheel drive motor available. To reduce overall motor length and weight, all unnecessary material was removed from the housing and the valve was placed in the face of the rotor. The pressure-compensated balance plate allows the motor to maintain high volumetric efficiencies at startup and high mechanical efficiencies during running conditions. All of these features unite to make the CE Series motor 10-25% lighter and more compact than competitive designs, making it perfect for applications with strict weight and size requirements.

FEATURES / BENEFITS

- Needle Roller Bearing is in optimum location to allow load to be placed as close to center line of bearing as possible.
- Three Bearing Options allow load carrying capability of motor to be matched to application.
- Valve-In-Rotor Design provides cost effective, efficient distribution of oil and reduces overall motor length.
- Pressure-Compensated Balance Plate improves volumetric efficiency at low flows and high pressure.

TYPICAL APPLICATIONS

Medium-duty wheel drives, grapple heads, feed rollers, broom drives and more

SERIES DESCRIPTIONS

400/401 - Hydraulic Motor
Standard

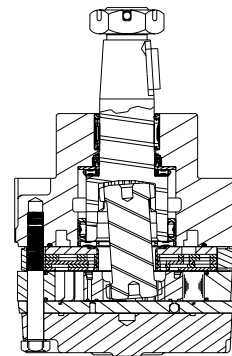

410/411 - Hydraulic Motor
With Integral Drum Brake

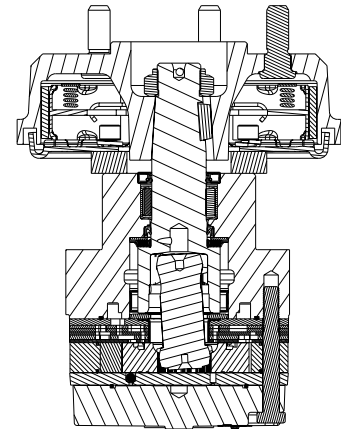

420/421 - Hydraulic Motor
With Medium Duty Bearing

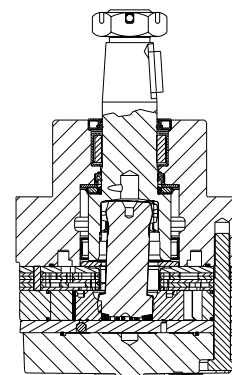

430/431 - Hydraulic Motor
With Heavy Duty Bearing

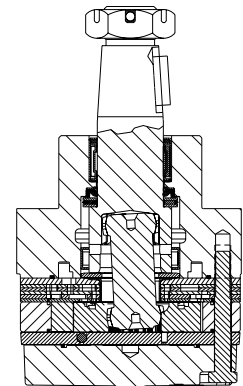

SPECIFICATIONS

CODE	Displacement cm ³ [in ³ /rev]	Max. Speed rpm		Max. Flow lpm [gpm]		Max. Torque Nm [lb-in]		Max. Pressure bar [psi]		
		cont.	inter.	cont.	inter.	cont.	inter.	cont.	inter.	peak
120	121 [7.4]	360	490	45 [12]	61 [16]	322 [2850]	356 [3150]	207 [3000]	224 [3250]	241 [3500]
160	162 [9.9]	370	470	61 [16]	76 [20]	424 [3750]	501 [4430]	207 [3000]	224 [3250]	241 [3500]
200	204 [12.4]	300	370	61 [16]	76 [20]	525 [4650]	593 [5250]	207 [3000]	224 [3250]	241 [3500]
230	232 [14.2]	260	320	61 [16]	76 [20]	559 [4950]	646 [5720]	207 [3000]	224 [3250]	241 [3500]
260	261 [15.9]	260	350	68 [18]	91 [24]	706 [6250]	760 [6730]	207 [3000]	224 [3250]	241 [3500]
300	300 [18.3]	250	320	76 [20]	95 [25]	802 [7100]	862 [7630]	207 [3000]	224 [3250]	241 [3500]
350	348 [21.2]	220	270	76 [20]	95 [25]	904 [8000]	1017 [9000]	207 [3000]	224 [3250]	241 [3500]
375	375 [22.8]	200	250	76 [20]	95 [25]	972 [8600]	1040 [9200]	207 [3000]	224 [3250]	241 [3500]
470	465 [28.3]	160	200	76 [20]	95 [25]	1040 [9200]	1153 [10200]	172 [2500]	189 [2750]	207 [3000]
540	536 [32.7]	140	170	76 [20]	95 [25]	1003 [8875]	1209 [10700]	138 [2000]	172 [2500]	207 [3000]
750	748 [45.6]	100	130	76 [20]	95 [25]	1082 [9575]	1237 [10950]	103 [1500]	121 [1750]	138 [2000]

▶ Performance data is typical. Performance of production units varies slightly from one motor to another. See page 6 for additional information on product testing. Running at intermittent ratings should not exceed 10% of every minute of operation.

DISPLACEMENT PERFORMANCE

120		Pressure - bar [psi]						Max. Cont.	Peak	
		17 [250]	35 [500]	69 [1000]	104 [1500]	138 [2000]	173 [2500]	207 [3000]	241 [3500]	
121 cm ³ [7.4 in ³] / rev										
Flow - lpm [gpm]		Torque - Nm [lb-in], Speed rpm						Intermittent Ratings - 10% of Operation		
		21 [184] 14	47 [418] 13	84 [745] 10	114 [1008] 7					16
Max. Cont.	4 [1]	26 [226] 26	52 [459] 26	109 [969] 23	157 [1387] 21	203 [1793] 18	260 [2305] 13	290 [2566] 10	281 [2490] 7	32
	8 [2]		52 [456] 58	110 [977] 56	161 [1424] 51	208 [1845] 47	269 [2382] 33	310 [2746] 29	347 [3066] 25	63
	15 [4]		48 [422] 119	110 [975] 112	169 [1497] 103	225 [1992] 95	271 [2399] 91	327 [2896] 83	369 [3269] 82	125
	23 [6]		46 [409] 187	106 [934] 182	158 [1402] 177	204 [1803] 173	248 [2199] 168	297 [2630] 160	372 [3290] 143	188
	30 [8]			99 [876] 248	157 [1389] 244	207 [1829] 240	253 [2241] 233	323 [2857] 205	371 [3282] 201	250
	38 [10]			96 [853] 306	156 [1379] 298	207 [1834] 293	257 [2278] 286	297 [2633] 279	359 [3178] 269	313
	45 [12]			85 [749] 371	151 [1337] 360	206 [1823] 352	256 [2267] 345	305 [2695] 341	344 [3042] 335	375
	53 [14]			77 [684] 437	137 [1215] 428	197 [1745] 418	251 [2222] 409	296 [2618] 404		438
	61 [16]			71 [633] 499	135 [1191] 490	194 [1717] 482	244 [2163] 467	304 [2687] 454		500
	Rotor Width	Overall Efficiency - 70 - 100% <input type="checkbox"/> 40 - 69% <input type="checkbox"/> 0 - 39% <input checked="" type="checkbox"/>								
Theoretical Torque - Nm [lb-in]										
13.8 [542]		33 [295]	67 [589]	133 [1178]	200 [1768]	266 [2357]	333 [2946]	399 [3535]	466 [4124]	
mm [in]		Displacement tested at 54°C [129°F] with an oil viscosity of 46cSt [213 SUS]								

160		Pressure - bar [psi]						Max. Cont.	Peak	
		17 [250]	35 [500]	69 [1000]	104 [1500]	138 [2000]	173 [2500]	207 [3000]	241 [3500]	
162 cm ³ [9.9 in ³] / rev										
Flow - lpm [gpm]		Torque - Nm [lb-in], Speed rpm						Intermittent Ratings - 10% of Operation		
		32 [287] 11	72 [634] 11	152 [1341] 10	215 [1906] 9	282 [2493] 8	326 [2888] 6	366 [3238] 4	412 [3643] 1	12
Max. Cont.	4 [1]	36 [318] 22	78 [690] 21	145 [1287] 20	225 [1991] 19	290 [2567] 16	346 [3060] 14	366 [3236] 8	416 [3680] 7	24
	8 [2]	33 [296] 45	73 [649] 44	145 [1287] 43	227 [2010] 40	292 [2586] 36	357 [3156] 33	413 [3654] 31	464 [4108] 28	47
	15 [4]	44 [386] 92	71 [630] 91	146 [1296] 88	226 [2000] 86	299 [2646] 79	364 [3226] 74	426 [3768] 71	485 [4289] 66	94
	23 [6]		70 [623] 133	146 [1294] 131	225 [1991] 128	296 [2617] 122	365 [3232] 117	428 [3786] 115	492 [4352] 111	140
	30 [8]		66 [583] 181	141 [1251] 177	216 [1916] 175	286 [2533] 171	350 [3102] 165	414 [3663] 159	476 [4210] 152	187
	38 [10]		61 [537] 224	138 [1224] 223	212 [1873] 219	282 [2497] 213	347 [3072] 211	411 [3641] 204	473 [4183] 196	234
	45 [12]		56 [495] 272	130 [1150] 265	207 [1829] 264	279 [2465] 262	344 [3046] 256	407 [3603] 249	470 [4157] 242	280
	53 [14]			123 [1088] 318	196 [1737] 313	269 [2384] 306	332 [2939] 297	400 [3540] 295	464 [4111] 284	327
	61 [16]			114 [1010] 362	187 [1659] 356	263 [2327] 351	329 [2910] 344	395 [3499] 334	458 [4053] 330	374
	68 [18]			102 [903] 410	180 [1593] 407	250 [2209] 401	319 [2822] 385	389 [3438] 382		420
Rotor Width	Overall Efficiency - 70 - 100% <input type="checkbox"/> 40 - 69% <input type="checkbox"/> 0 - 39% <input checked="" type="checkbox"/>									
	Theoretical Torque - Nm [lb-in]									
13.8 [542]		45 [394]	89 [788]	178 [1576]	267 [2365]	356 [3153]	445 [3941]	534 [4729]	623 [5518]	
mm [in]		Displacement tested at 54°C [129°F] with an oil viscosity of 46cSt [213 SUS]								

► Performance data is typical. Performance of production units varies slightly from one motor to another. Operating at maximum continuous pressure and maximum continuous flow simultaneously is not recommended. For additional information on product testing please refer to page 6.

DISPLACEMENT PERFORMANCE

		Pressure - bar [psi]						Max. Cont.	Peak
200		17 [250]	35 [500]	69 [1000]	104 [1500]	138 [2000]	173 [2500]	207 [3000]	241 [3500]
204 cm ³ [12.4 in ³] / rev		Torque - Nm [lb-in], Speed rpm						Intermittent Ratings - 10% of Operation	
Flow - lpm [gpm]	2 [0.5]	40 [358] 8	92 [817] 8	180 [1596] 8	269 [2378] 7	348 [3083] 6			10
	4 [1]	46 [409] 17	89 [787] 15	180 [1597] 15	276 [2440] 12	359 [3177] 11	427 [3782] 9	489 [4328] 8	19
	8 [2]	45 [395] 36	91 [807] 34	190 [1684] 32	284 [2509] 31	369 [3268] 28	451 [3989] 25	523 [4630] 23	38
	15 [4]	40 [358] 73	92 [817] 72	188 [1662] 69	284 [2492] 67	373 [3303] 63	453 [4006] 60	530 [4693] 56	75
	23 [6]		86 [760] 111	181 [1600] 107	278 [2457] 104	365 [3228] 100	451 [3989] 95	524 [4636] 90	112
	30 [8]		75 [663] 148	174 [1539] 145	267 [2363] 142	359 [3176] 137	441 [3905] 132	518 [4584] 125	150
	38 [10]		62 [549] 185	162 [1430] 184	257 [2272] 181	347 [3072] 177	429 [3798] 171	507 [4488] 164	187
	45 [12]			146 [1290] 222	244 [2159] 217	339 [2996] 213	429 [3798] 204	506 [4476] 198	224
	53 [14]			129 [1145] 259	227 [2005] 256	328 [2905] 250	410 [3628] 244	492 [4354] 236	261
	61 [16]			112 [994] 298	208 [1842] 297	316 [2795] 284	399 [3534] 281	484 [4285] 273	299
68 [18]			90 [799] 334	207 [1833] 330	304 [2689] 327	395 [3493] 320	481 [4260] 316	336	
76 [20]			75 [665] 366	178 [1576] 365	282 [2495] 361	372 [3288] 361	465 [4115] 351	373	
Max. Cont.									
Max. Inter.									
Rotor Width		Overall Efficiency - 70 - 100%		40 - 69%		0 - 39%			
Theoretical Torque - Nm [lb-in]									
17.3 [682] mm [in]		56 [494]	112 [987]	223 [1975]	335 [2962]	446 [3949]	558 [4936]	669 [5924]	781 [6911]
Displacement tested at 54°C [129°F] with an oil viscosity of 46cSt [213 SUS]									

		Pressure - bar [psi]						Max. Cont.	Peak
230		17 [250]	35 [500]	69 [1000]	104 [1500]	138 [2000]	173 [2500]	207 [3000]	241 [3500]
233 cm ³ [14.2 in ³] / rev		Torque - Nm [lb-in], Speed rpm						Intermittent Ratings - 10% of Operation	
Flow - lpm [gpm]	2 [0.5]	46 [406] 7	98 [866] 7	209 [1849] 6	300 [2659] 5	380 [3367] 2			9
	4 [1]	49 [435] 14	105 [925] 13	215 [1903] 12	321 [2839] 11	413 [3651] 8	488 [4315] 6	543 [4808] 3	17
	8 [2]	50 [438] 30	107 [945] 28	221 [1954] 26	329 [2909] 26	430 [3803] 22	520 [4599] 18	594 [5260] 13	33
	15 [4]	45 [401] 62	102 [900] 61	214 [1895] 59	325 [2872] 57	426 [3773] 53	522 [4623] 47	610 [5395] 41	66
	23 [6]	39 [342] 96	92 [812] 96	203 [1801] 93	317 [2808] 91	412 [3645] 87	486 [4304] 80	560 [4953] 72	98
	30 [8]		84 [743] 128	197 [1739] 125	304 [2691] 122	410 [3627] 119	506 [4479] 112	600 [5313] 103	131
	38 [10]		72 [634] 162	186 [1650] 159	292 [2585] 156	402 [3556] 153	493 [4363] 146	584 [5169] 136	163
	45 [12]			167 [1477] 192	282 [2494] 191	393 [3479] 185	491 [4349] 178	576 [5094] 167	196
	53 [14]			152 [1343] 225	260 [2301] 225	374 [3310] 220	470 [4160] 208	555 [4910] 201	228
	61 [16]			135 [1198] 259	250 [2209] 259	362 [3207] 253	464 [4110] 244	553 [4895] 232	261
68 [18]			115 [1021] 291	231 [2044] 289	344 [3042] 286	447 [3956] 279	540 [4777] 266	293	
76 [20]			93 [822] 325	210 [1859] 323	327 [2898] 319	432 [3825] 311	529 [4677] 299	326	
Max. Cont.									
Max. Inter.									
Rotor Width		Overall Efficiency - 70 - 100%		40 - 69%		0 - 39%			
Theoretical Torque - Nm [lb-in]									
19.7 [777] mm [in]		64 [565]	128 [1131]	256 [2261]	383 [3392]	511 [4522]	639 [5653]	767 [6783]	894 [7914]
Displacement tested at 54°C [129°F] with an oil viscosity of 46cSt [213 SUS]									

► Performance data is typical. Performance of production units varies slightly from one motor to another. Operating at maximum continuous pressure and maximum continuous flow simultaneously is not recommended. For additional information on product testing please refer to page 6.

DISPLACEMENT PERFORMANCE

		Pressure - bar [psi]						Max. Cont.	Peak		
260		17 [250]	35 [500]	69 [1000]	104 [1500]	138 [2000]	173 [2500]	207 [3000]	241 [3500]		
261 cm ³ [15.9 in ³] / rev											
		Torque - Nm [lb-in], Speed rpm						Intermittent Ratings - 10% of Operation			
Flow - lpm [gpm]	Max. Cont.	2 [0.5]	58 [514] 6	127 [1120] 5	242 [2140] 4	347 [3068] 3	425 [3759] 1			Theoretical rpm	
		4 [1]	62 [547] 12	124 [1097] 10	248 [2191] 9	354 [3133] 8	446 [3950] 6	495 [4377] 2			
		8 [2]	61 [543] 26	130 [1150] 23	249 [2200] 20	372 [3295] 20	478 [4234] 17	562 [4972] 13	633 [5599] 7		
		15 [4]	61 [536] 54	125 [1109] 51	258 [2284] 48	377 [3339] 46	501 [4436] 42	600 [5306] 36	700 [6192] 30		781 [6915] 21
		23 [6]	57 [500] 84	121 [1067] 81	245 [2169] 74	376 [3326] 74	498 [4406] 69	609 [5391] 60	713 [6309] 53		815 [7214] 45
		30 [8]		111 [981] 113	242 [2143] 107	369 [3268] 105	489 [4327] 100	607 [5374] 89	711 [6290] 81		810 [7167] 71
		38 [10]		103 [909] 142	230 [2034] 137	357 [3161] 134	483 [4273] 128	595 [5267] 119	700 [6198] 109		762 [6740] 98
		45 [12]		87 [771] 173	216 [1915] 169	345 [3057] 166	452 [4002] 161	578 [5111] 152	645 [5708] 143		741 [6557] 129
		53 [14]		75 [664] 203	202 [1786] 201	331 [2928] 195	434 [3841] 191	553 [4897] 183	657 [5811] 170		759 [6718] 157
		61 [16]		61 [538] 232	191 [1687] 131	313 [2769] 226	435 [3847] 220	553 [4892] 210	656 [5803] 199		746 [6601] 189
68 [18]			168 [1486] 258	295 [2614] 255	414 [3664] 248	526 [4652] 242	638 [5642] 229	742 [6567] 215			
76 [20]			152 [1345] 287	277 [1455] 286	403 [3570] 281	520 [4598] 271	631 [5585] 257				
83 [22]			129 [1143] 319	249 [2208] 319	381 [3372] 312	493 [4365] 299	620 [5489] 287				
91 [24]			104 [924] 348	233 [2063] 346	358 [3166] 335	471 [4168] 333	551 [4875] 332				
Overall Efficiency - 70 - 100% <input type="checkbox"/> 40 - 69% <input type="checkbox"/> 0 - 39% <input checked="" type="checkbox"/>											
Rotor Width Theoretical Torque - Nm [lb-in]											
22.1 [0.872] mm [in]		72 [633]	143 [1266]	286 [2532]	429 [3798]	572 [5064]	715 [6330]	858 [7596]	1001 [8861]		
Displacement tested at 54°C [129°F] with an oil viscosity of 46cSt [213 SUS]											

		Pressure - bar [psi]						Max. Cont.	Peak		
300		17 [250]	35 [500]	69 [1000]	104 [1500]	138 [2000]	173 [2500]	207 [3000]	241 [3500]		
300 cm ³ [18.3 in ³] / rev											
		Torque - Nm [lb-in], Speed rpm						Intermittent Ratings - 10% of Operation			
Flow - lpm [gpm]	Max. Cont.	2 [0.5]	63 [559] 5	136 [1202] 4	285 [2518] 3	413 [3656] 3	513 [4537] 2	580 [5129] 1		Theoretical rpm	
		4 [1]	56 [493] 12	139 [1230] 10	272 [2410] 10	386 [3418] 8	483 [4272] 6	546 [4834] 4			
		8 [2]	59 [522] 23	134 [1185] 21	302 [2676] 19	427 [3781] 19	521 [4611] 16	587 [5196] 14	673 [5952] 10		743 [6572] 5
		15 [4]	57 [503] 47	134 [1189] 44	296 [2620] 40	407 [3602] 38	497 [4398] 37	602 [5324] 34	696 [6161] 29		774 [6852] 23
		23 [6]	50 [447] 73	125 [1109] 70	286 [2534] 64	439 [3886] 62	559 [4946] 61	677 [5992] 55	789 [6978] 48		877 [7762] 43
		30 [8]		111 [986] 97	279 [2468] 93	424 [3752] 92	567 [5020] 86	685 [6059] 77	807 [7142] 72		920 [8139] 64
		38 [10]		96 [853] 126	261 [2306] 121	417 [3687] 118	532 [4712] 112	659 [5832] 104	805 [7121] 95		903 [7994] 86
		45 [12]		78 [689] 150	228 [2013] 149	367 [3252] 146	501 [4434] 140	643 [5694] 130	766 [6781] 121		890 [7875] 109
		53 [14]		59 [525] 176	213 [1889] 174	385 [3410] 171	495 [4383] 166	623 [5509] 155	748 [6618] 143		812 [7186] 136
		61 [16]			181 [1603] 200	349 [3085] 196	474 [4195] 194	620 [5484] 181	731 [6471] 172		850 [7519] 157
68 [18]			159 [1405] 227	319 [2823] 225	479 [4241] 219	578 [5112] 212	718 [6356] 196	830 [7348] 186			
76 [20]			126 [1115] 252	289 [2560] 251	418 [3703] 248	561 [4962] 240	703 [6221] 225	811 [7180] 207			
83 [22]			104 [919] 277	261 [2309] 276	390 [3454] 274	555 [4907] 263	679 [6011] 252				
91 [24]			67 [590] 302	218 [1925] 301	389 [3441] 299	530 [4686] 293	652 [5766] 282				
95 [25]			56 [496] 314	197 [1740] 313	364 [3225] 310	484 [4281] 309	632 [5594] 298				
Overall Efficiency - 70 - 100% <input type="checkbox"/> 40 - 69% <input type="checkbox"/> 0 - 39% <input checked="" type="checkbox"/>											
Rotor Width Theoretical Torque - Nm [lb-in]											
25.4 [1.000] mm [in]		82 [729]	165 [1457]	329 [2914]	494 [4371]	659 [5828]	823 [7285]	988 [8742]	1152 [10199]		
Displacement tested at 54°C [129°F] with an oil viscosity of 46cSt [213 SUS]											

► Performance data is typical. Performance of production units varies slightly from one motor to another. Operating at maximum continuous pressure and maximum continuous flow simultaneously is not recommended. For additional information on product testing please refer to page 6.

DISPLACEMENT PERFORMANCE

		Pressure - bar [psi]						Max. Cont.	Peak	
350		17 [250]	35 [500]	69 [1000]	104 [1500]	138 [2000]	173 [2500]	207 [3000]	241 [3500]	
348 cm ³ [21.2 in ³] / rev		Intermittent Ratings - 10% of Operation								
Torque - Nm [lb-in], Speed rpm										
Flow - lpm [gpm]	2 [0.5]	70 [617] 5	147 [1297] 5	269 [2383] 4					6	
	4 [1]	73 [649] 10	149 [1318] 10	291 [2580] 10	412 [3647] 9				11	
	8 [2]	76 [670] 21	159 [1403] 21	313 [2767] 21	453 [4007] 20	557 [4927] 18	668 [5915] 16	782 [6919] 13	22	
	15 [4]	69 [609] 43	159 [1409] 42	324 [2868] 42	463 [4101] 40	596 [5273] 37	714 [6316] 36	820 [7261] 32	927 [8204] 25	44
	23 [6]	62 [544] 65	149 [1319] 65	321 [2837] 64	478 [4228] 31	606 [5363] 57	736 [6514] 53	845 [7475] 52	950 [8410] 43	66
	30 [8]	45 [395] 87	128 [1134] 86	304 [2693] 85	467 [4134] 84	622 [5502] 80	776 [6870] 75	906 [8022] 67	987 [8734] 61	88
	38 [10]		109 [962] 108	288 [2550] 107	455 [4027] 106	621 [5500] 100	754 [6670] 94	907 [8028] 85	1029 [9105] 77	109
	45 [12]		94 [833] 130	268 [2376] 129	439 [3889] 128	588 [5205] 124	758 [6712] 115	901 [7970] 104	1031 [9120] 94	131
	53 [14]		65 [575] 152	244 [2162] 151	409 [3619] 150	572 [5059] 148	727 [6433] 137	879 [7777] 127	1025 [9070] 117	153
	61 [16]			220 [1947] 174	385 [3406] 173	549 [4855] 171	697 [6172] 163	855 [7570] 152	1000 [8853] 139	175
	68 [18]			186 [1644] 196	361 [3195] 194	520 [4599] 192	685 [6062] 187	825 [7297] 177	967 [8555] 165	197
	76 [20]			147 [1301] 216	324 [2863] 213	483 [4275] 212	637 [5634] 209	790 [6993] 194	944 [8357] 183	218
	83 [22]			109 [960] 239	289 [2560] 237	443 [3921] 234	605 [5357] 232	770 [6814] 223		240
91 [24]			77 [684] 261	251 [2225] 258	431 [3814] 257	588 [5207] 256	733 [6488] 248		262	
95 [25]			56 [493] 272	226 [2004] 270	409 [3621] 264	570 [5048] 261	727 [6435] 259		273	
	Max. Cont.									
	Max. Inter.									
	Rotor Width									
	39.4 [1.553] mm [in]									
	Overall Efficiency - 70 - 100%	<input type="checkbox"/>	<input type="checkbox"/>	<input type="checkbox"/>	<input type="checkbox"/>	<input type="checkbox"/>	<input type="checkbox"/>	<input type="checkbox"/>	<input type="checkbox"/>	
	Theoretical Torque - Nm [lb-in]									
		95 [844]	191 [1688]	381 [3376]	572 [5064]	763 [6752]	954 [8439]	1144 [10127]	1335 [11815]	
		Displacement tested at 54°C [129°F] with an oil viscosity of 46cSt [213 SUS]								

		Pressure - bar [psi]						Max. Cont.	Peak	
375		17 [250]	35 [500]	69 [1000]	104 [1500]	138 [2000]	173 [2500]	207 [3000]	241 [3500]	
375 cm ³ [22.8 in ³] / rev		Intermittent Ratings - 10% of Operation								
Torque - Nm [lb-in], Speed rpm										
Flow - lpm [gpm]	2 [0.5]	78 [687] 4	162 [1438] 4	321 [2840] 4	447 [3958] 3	592 [5237] 2			6	
	4 [1]	78 [694] 9	163 [1443] 8	333 [2951] 8	474 [4193] 7	606 [5366] 6	730 [6457] 4		11	
	8 [2]	81 [721] 19	169 [1495] 18	339 [3001] 17	485 [4288] 16	625 [5533] 15	756 [6692] 13	851 [7532] 9	21	
	15 [4]	74 [651] 39	166 [1470] 38	321 [2837] 36	465 [4117] 36	611 [5404] 33	748 [6624] 29	876 [7754] 26	991 [8766] 25	41
	23 [6]	62 [547] 60	155 [1372] 59	341 [3015] 58	515 [4557] 56	670 [5931] 51	785 [6946] 44	884 [7825] 40	1005 [8896] 43	61
	30 [8]	47 [412] 81	138 [1223] 80	320 [2836] 77	503 [4453] 76	664 [5880] 71	834 [7385] 63	976 [8633] 55	1067 [9442] 61	82
	38 [10]		118 [1048] 101	303 [2684] 99	495 [4382] 97	647 [5726] 92	801 [7090] 83	922 [8161] 74	1058 [9364] 77	102
	45 [12]		98 [870] 121	288 [2547] 119	469 [4147] 117	635 [5620] 112	804 [7115] 107	972 [8605] 93	1121 [9920] 94	122
	53 [14]		71 [625] 141	261 [2308] 140	435 [3849] 139	603 [5337] 135	786 [6953] 126	938 [8298] 114	1104 [9771] 117	142
	61 [16]		55 [487] 162	241 [2134] 161	423 [3744] 160	593 [5248] 155	758 [6706] 147	922 [8160] 135	1086 [9614] 139	163
	68 [18]			204 [1805] 182	391 [3461] 181	564 [4988] 177	723 [6402] 168	893 [7899] 164	1053 [9320] 165	183
	76 [20]			219 [1942] 201	365 [3231] 200	533 [4714] 198	662 [5860] 193	864 [7643] 178	1030 [9112] 183	203
	83 [22]			132 [1173] 222	316 [2795] 220	514 [4552] 219	675 [5970] 210	807 [7141] 203		223
91 [24]			100 [881] 243	290 [2567] 242	475 [4202] 241	640 [5667] 232	792 [7012] 220		244	
95 [25]			80 [711] 253	261 [2313] 251	465 [4113] 250	616 [5454] 242	779 [6891] 235		254	
	Max. Cont.									
	Max. Inter.									
	Rotor Width									
	31.8 [1.252] mm [in]									
	Overall Efficiency - 70 - 100%	<input type="checkbox"/>	<input type="checkbox"/>	<input type="checkbox"/>	<input type="checkbox"/>	<input type="checkbox"/>	<input type="checkbox"/>	<input type="checkbox"/>	<input type="checkbox"/>	
	Theoretical Torque - Nm [lb-in]									
		103 [908]	205 [1815]	410 [3631]	615 [5446]	821 [7261]	1026 [9076]	1231 [10892]	1436 [12707]	
		Displacement tested at 54°C [129°F] with an oil viscosity of 46cSt [213 SUS]								

► Performance data is typical. Performance of production units varies slightly from one motor to another. Operating at maximum continuous pressure and maximum continuous flow simultaneously is not recommended. For additional information on product testing please refer to page 6.

DISPLACEMENT PERFORMANCE

		Pressure - bar [psi]					Max. Cont.		Peak		
750		17 [250]	35 [500]	69 [1000]	104 [1500]	138 [2000]					
748 cm ³ [45.6 in ³] / rev							Intermittent Ratings - 10% of Operation				
		Torque - Nm [lb-in], Speed rpm									
Flow - lpm [gpm]	2 [0.5]	108 [957] 2	231 [2041] 1							3	
	4 [1]	174 [1540] 4	340 [3010] 4	651 [5760] 4	950 [8408] 4	1233 [10916] 3				6	
	8 [2]	166 [1467] 9	367 [3246] 9	695 [6154] 9	1020 [9024] 9	1302 [11518] 7				11	
	15 [4]	170 [1501] 19	359 [3181] 19	719 [6366] 19	1086 [9607] 18	1325 [11729] 16				21	
	23 [6]	167 [1477] 29	344 [3048] 29	699 [6190] 28	1015 [8979] 27	1346 [11916] 25				31	
	30 [8]	129 [1142] 40	324 [2866] 39	700 [6191] 38	1053 [9316] 37	1345 [11898] 35				41	
	38 [10]	111 [979] 50	295 [2606] 49	656 [5809] 48	1039 [9191] 47	1390 [12305] 44				51	
	45 [12]	69 [614] 60	254 [2246] 59	631 [5586] 58	987 [8736] 57	1365 [12079] 56				61	
	53 [14]	47 [413] 69	227 [2009] 68	591 [5232] 66	957 [8469] 65	1346 [11913] 64				71	
	61 [16]		198 [1756] 80	555 [4909] 79	931 [8243] 77	1294 [11455] 74				82	
	68 [18]		136 [1203] 91	517 [4571] 90	879 [7778] 90	1230 [10884] 87				92	
	76 [20]		93 [827] 100	453 [4010] 99	820 [7257] 98	1191 [10540] 97				102	
	83 [22]			409 [3620] 109	786 [6958] 108					112	
	91 [24]			340 [3010] 120	747 [6609] 119					122	
	95 [25]			318 [2810] 126	693 [6130] 125					127	
Max. Cont.											
Max. Inter.											
		Overall Efficiency - 70 - 100% <input type="checkbox"/> 40 - 69% <input type="checkbox"/> 0 - 39% <input type="checkbox"/>									
Rotor Width		Theoretical Torque - Nm [lb-in]									
63.5 [2.501]		205 [1815]	410 [3631]	821 [7261]	1231 [10892]	1641 [14522]					
mm [in]		Displacement tested at 54°C [129°F] with an oil viscosity of 46cSt [213 SUS]									

► Performance data is typical. Performance of production units varies slightly from one motor to another. Operating at maximum continuous pressure and maximum continuous flow simultaneously is not recommended. For additional information on product testing please refer to page 6.

HOUSINGS

► Dimensions shown are without paint. Paint thickness can be up to 0.13 [.005].

4-HOLE, WHEEL MOUNT, ALIGNED PORTS

W31 7/8-14 UNF **W38** G 1/2

STANDARD

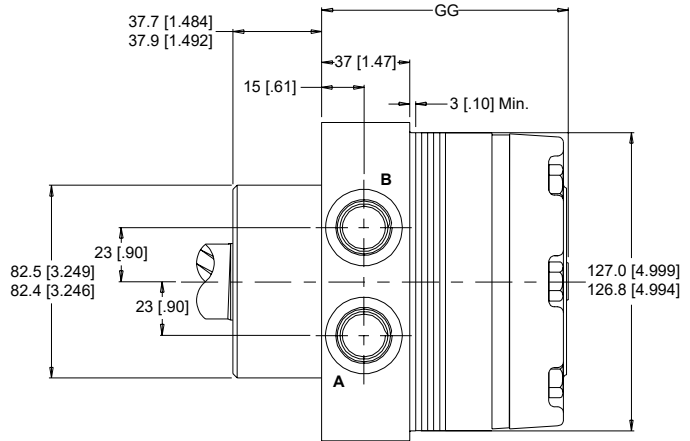
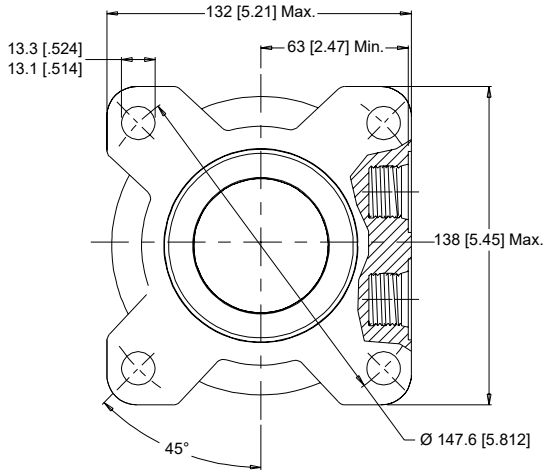

OPTIONAL VALVE CAVITY

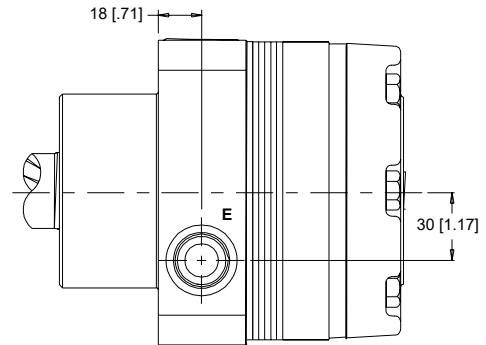
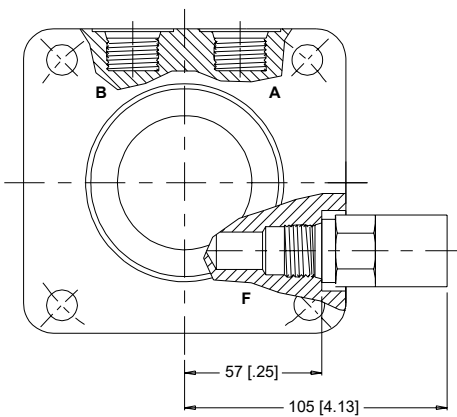

E: 10 Series/2-Way Valve Cavity 7/8-14 UNF **F:** Valve Cartridge Installed

► Dimension GG is charted on page 24.

TECHNICAL INFORMATION

ALLOWABLE SHAFT LOAD / BEARING CURVE

The bearing curve represents allowable bearing loads based on ISO 281 bearing capacity for an L_{10} life of 2,000 hours at 100 rpm. Radial loads for speeds other than 100 rpm may be calculated using the multiplication factor table on page 7.

WHEEL MOUNTS

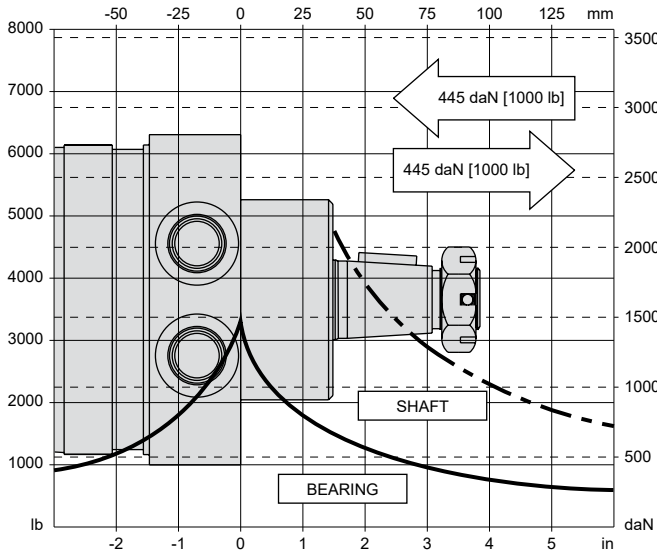

LENGTH & WEIGHT CHART

Dimension GG is the overall motor length from the rear of the motor to the mounting flange surface and is referenced on detailed housing drawings listed on pages 23, 29 & 32.

GG #	Length mm [in]	Weight kg [lb]
120	101 [3.98]	10.9 [24.1]
160	101 [3.98]	10.9 [24.1]
200	105 [4.12]	11.3 [24.8]
230	107 [4.21]	11.4 [25.2]
260	109 [4.31]	11.6 [25.6]
300	113 [4.44]	11.9 [26.3]
350	116 [4.56]	13.1 [28.8]
375	119 [4.69]	12.4 [27.4]
470	127 [4.99]	13.1 [28.8]
540	134 [5.30]	13.6 [30.0]
750	151 [5.94]	15.0 [33.1]

► All CE series motor weights can vary ± 0.5 kg [1 lb] depending on model configurations such as housing, shaft, endcover, options etc.

SHAFTS

20 1-1/4" Straight

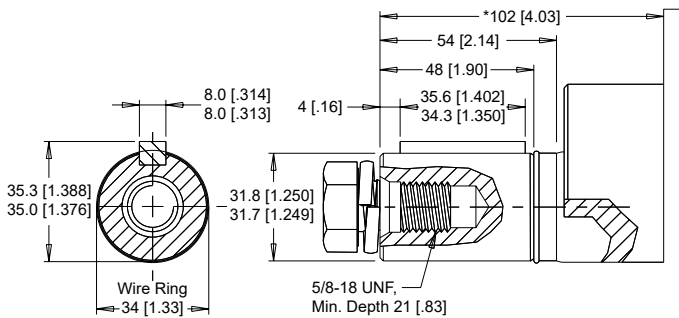

Max. Torque: 1200 Nm [10600 lb-in]

22 1-1/4" Tapered

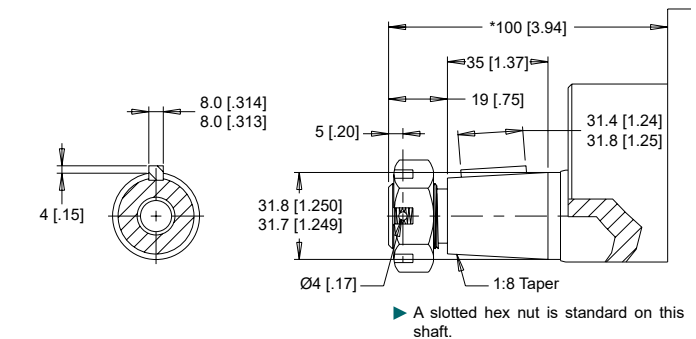

Max. Torque: 1200 Nm [10600 lb-in]

23 14 Tooth Spline

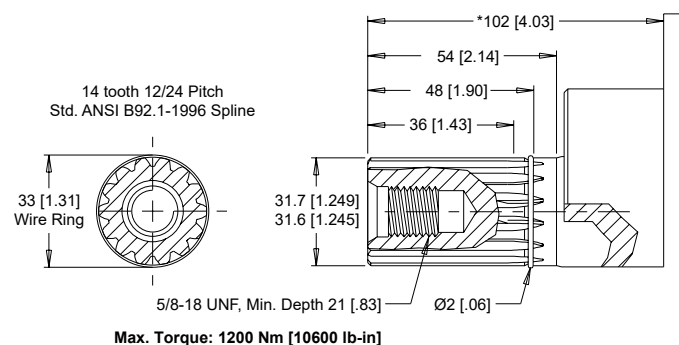

Max. Torque: 1200 Nm [10600 lb-in]

ORDERING INFORMATION

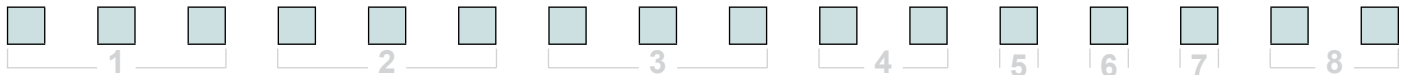

1. CHOOSE SERIES DESIGNATION

400 Standard Rotation

401 Reverse Rotation

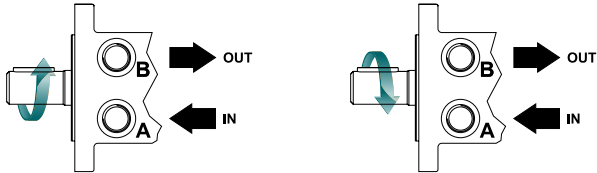

► The 400 & 401 series are bi-directional. For applications requiring the motor to rotate in only one direction, shaft seal life may be prolonged by pressurizing the A port of the motor.

2. SELECT A DISPLACEMENT OPTION

120	121 cm ³ /rev [7.4 in ³ /rev]	350	348 cm ³ /rev [21.2 in ³ /rev]
160	162 cm ³ /rev [9.9 in ³ /rev]	375	375 cm ³ /rev [22.8 in ³ /rev]
200	204 cm ³ /rev [12.4 in ³ /rev]	470	465 cm ³ /rev [28.3 in ³ /rev]
230	232 cm ³ /rev [14.2 in ³ /rev]	540	536 cm ³ /rev [32.7 in ³ /rev]
260	261 cm ³ /rev [15.9 in ³ /rev]	750	748 cm ³ /rev [45.6 in ³ /rev]
300	300 cm ³ /rev [18.3 in ³ /rev]		

3. SELECT A MOUNT & PORT OPTION

W31	4-Hole, Wheel Mount, Aligned Ports, 7/8-14 UNF
W38	4-Hole, Wheel Mount, Aligned Ports, G 1/2

4. SELECT A SHAFT OPTION

20	1-1/4" Straight	23	14 Tooth Spline
22	1-1/4" Tapered		

5. SELECT A PAINT OPTION

A	Black
B	Black, Unpainted Mounting Surface
Z	No Paint

6. SELECT A VALVE CAVITY / CARTRIDGE OPTION

A	None	E	104 bar [1500 psi] Relief
B	Valve Cavity Only	F	121 bar [1750 psi] Relief
C	69 bar [1000 psi] Relief	G	138 bar [2000 psi] Relief
D	86 bar [1250 psi] Relief		

7. SELECT AN ADD-ON OPTION

A	Standard
B	Lock Nut
C	Solid Hex Nut

8. SELECT A MISCELLANEOUS OPTION

AA	None
AC	Freeturning Rotor
AE	Hydraulic Declutch with Freeturning Rotor

► For options not listed in the table above, please contact us with your requirements

HOUSINGS

► Dimensions shown are without paint. Paint thickness can be up to 0.13 [.005].

4-HOLE, WHEEL BRAKE MOUNT, ALIGNED PORTS

K31 7/8-14 UNF **K35** 9/16-18 UNF **K38** G 1/2

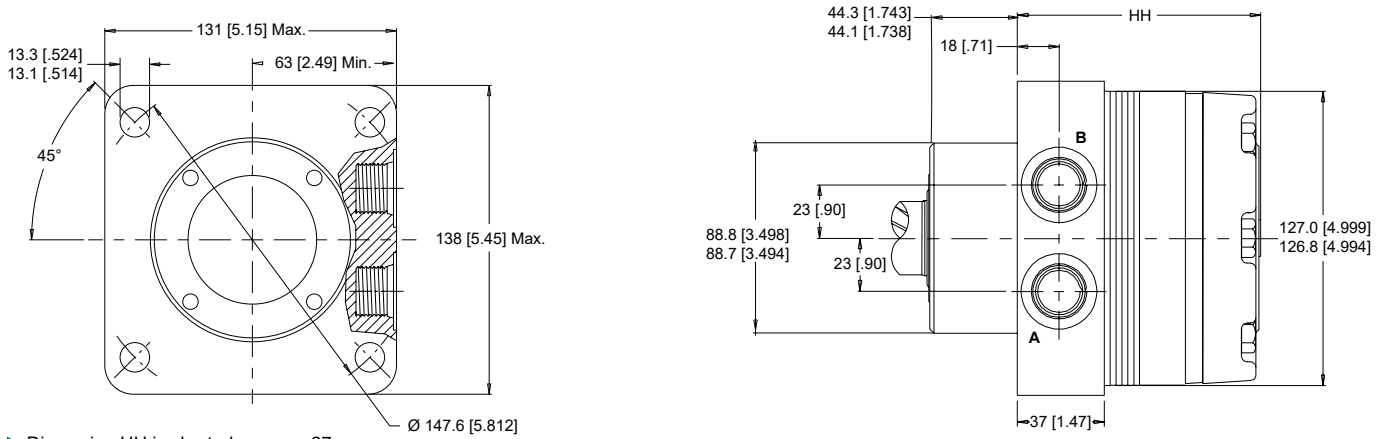

► Dimension HH is charted on page 27.

HUB OPTION DETAILS

5-BOLT, WHEEL HUB

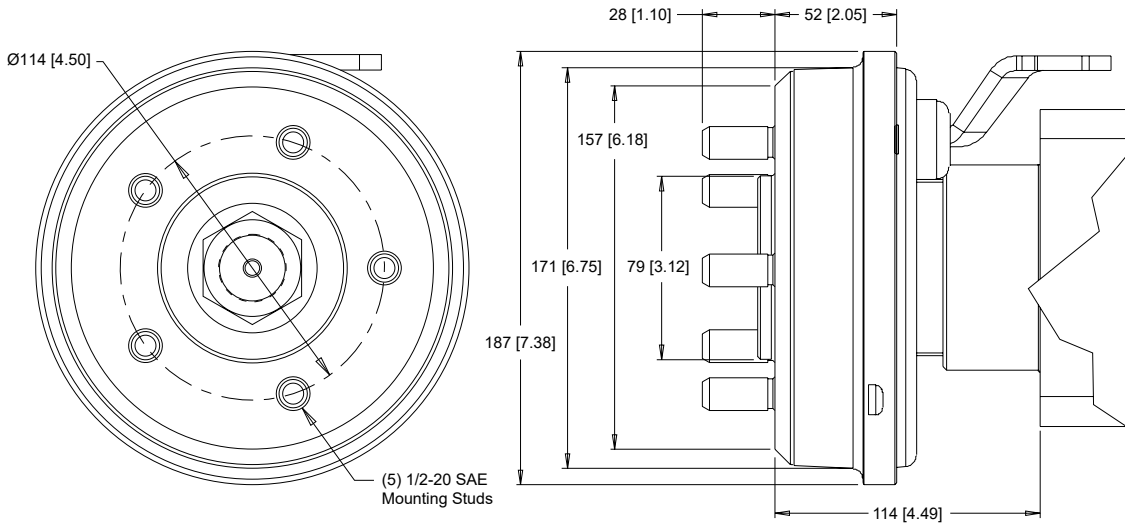

4-BOLT, WHEEL HUB

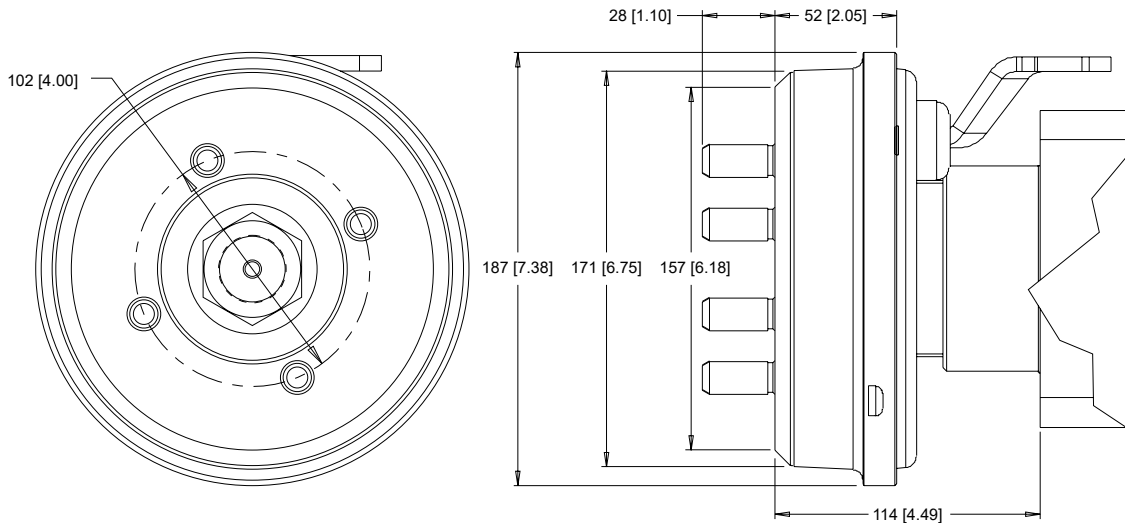

TECHNICAL INFORMATION

BRAKE LEVER POSITION & PULL DIRECTION

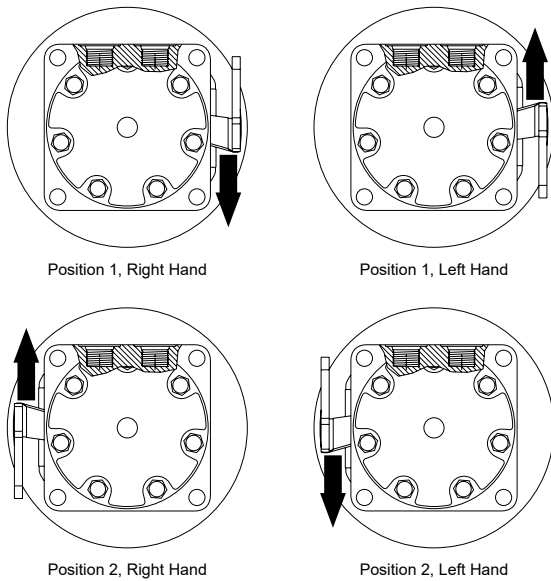

BRAKE HOLDING TORQUE

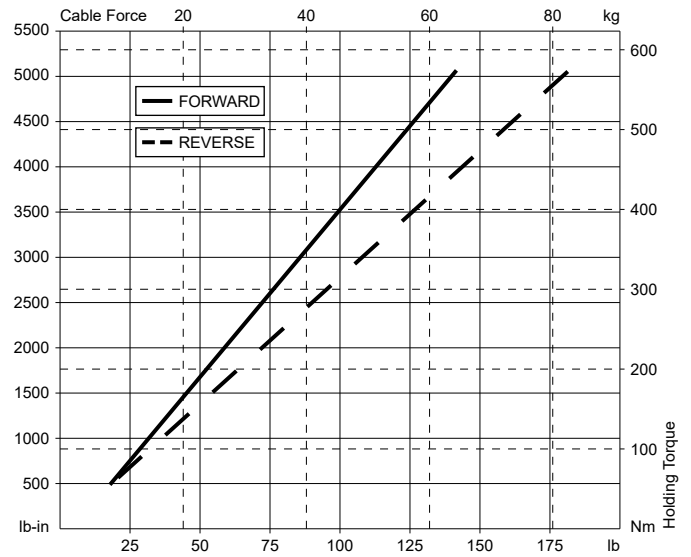

ALLOWABLE SHAFT LOAD / BEARING CURVE

The bearing curve represents allowable bearing loads based on ISO 281 bearing capacity for an L_{10} life of 2,000 hours at 100 rpm. Radial loads for speeds other than 100 rpm may be calculated using the multiplication factor table on page 7.

LENGTH & WEIGHT CHART

Dimension HH is the overall motor length from the rear of the motor to the mounting flange surface and is referenced on detailed housing drawings listed on page 26.

HH #	Length mm [in]	Weight kg [lb]
120	99 [3.91]	16.0 [35.2]
160	99 [3.91]	16.0 [35.2]
200	103 [4.05]	16.3 [35.9]
230	105 [4.15]	16.5 [36.3]
260	108 [4.24]	16.7 [36.7]
300	111 [4.37]	17.0 [37.4]
350	125 [4.92]	18.1 [39.9]
375	117 [4.62]	17.5 [38.5]
470	125 [4.92]	18.1 [39.9]
540	131 [5.16]	18.7 [41.1]
750	149 [5.87]	20.1 [44.2]

MOTOR BRAKE

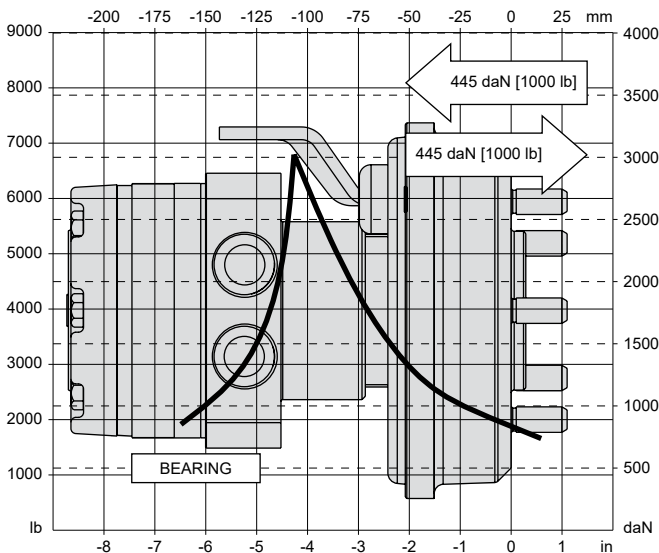

► 410/411 motor/brake weights can vary ± 0.5 kg [1 lb] depending on model configurations such as housing, shaft, endcover, options etc.

ORDERING INFORMATION

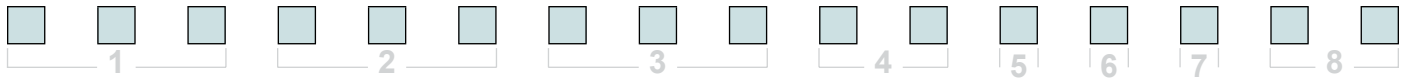

1. CHOOSE SERIES DESIGNATION

- 410** Counterclockwise Rotation
- 411** Clockwise Rotation

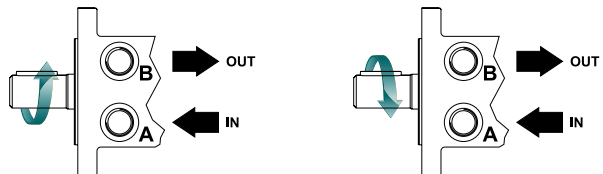

► The 410 & 411 series are bi-directional. Reversing the inlet hose will reverse shaft rotation. For applications requiring the motor to rotate in only one direction, shaft seal life may be prolonged by pressurizing the A port of the motor.

2. SELECT A DISPLACEMENT OPTION

120	121 cm ³ /rev [7.4 in ³ /rev]	350	348 cm ³ /rev [21.2 in ³ /rev]
160	162 cm ³ /rev [9.9 in ³ /rev]	375	375 cm ³ /rev [22.8 in ³ /rev]
200	204 cm ³ /rev [12.4 in ³ /rev]	470	465 cm ³ /rev [28.3 in ³ /rev]
230	232 cm ³ /rev [14.2 in ³ /rev]	540	536 cm ³ /rev [32.7 in ³ /rev]
260	261 cm ³ /rev [15.9 in ³ /rev]	750	748 cm ³ /rev [45.6 in ³ /rev]
300	300 cm ³ /rev [18.3 in ³ /rev]		

3. SELECT A MOUNT & PORT OPTION

- K31** 4-Hole, Wheel Brake Mount, Aligned Ports, 7/8-14 UNF
- K35** 4-Hole, Wheel Brake Mount, Aligned Ports, 9/16-18 UNF
- K38** 4-Hole, Wheel Brake Mount, Aligned Ports, G 1/2

4. SELECT A SHAFT OPTION

- 22** 1-1 /4" Tapered

5. SELECT A PAINT OPTION

- A** Black
- Z** No Paint

6. SELECT A VALVE CAVITY / CARTRIDGE OPTION

- A** None

7. SELECT AN ADD-ON OPTION

- A** Standard

8. SELECT A MISCELLANEOUS OPTION

- YA** 5 Bolt Hub, Position 2, Right Hand
- YB** 5 Bolt Hub, Position 2, Left Hand
- YE** 4 Bolt Hub, Position 2, Right Hand
- YF** 4 Bolt Hub, Position 2, Left Hand
- ZA** 5 Bolt Hub, Position 1, Left Hand
- ZB** 5 Bolt Hub, Position 1, Right Hand
- ZE** 4 Bolt Hub, Position 1, Left Hand
- ZF** 4 Bolt Hub, Position 1, Right Hand

► For options not listed in the table above, please contact us with your requirements

HOUSINGS

► Dimensions shown are without paint. Paint thickness can be up to 0.13 [.005].

4-HOLE, 3.25" PILOT WHEEL MOUNT, ALIGNED PORTS

P31 7/8-14 UNF **P38** G 1/2

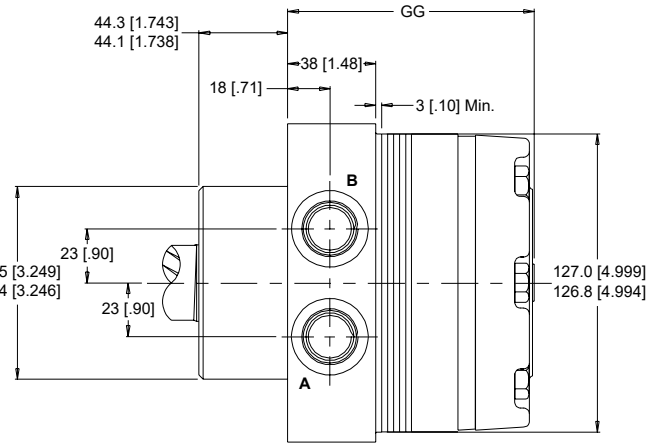
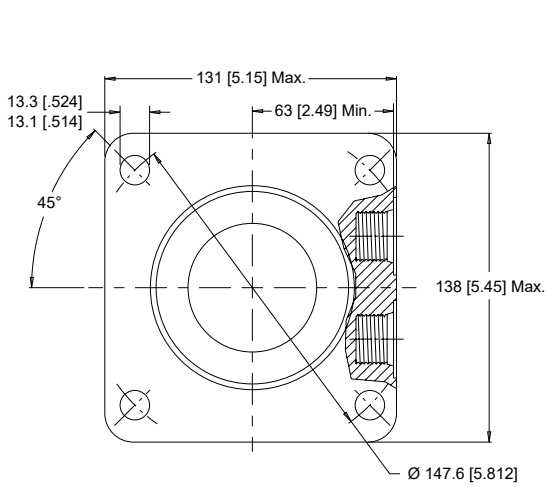

4-HOLE, 3.50" PILOT WHEEL MOUNT, ALIGNED PORTS

W31 7/8-14 UNF **W35** 9/16-18 UNF **W38** G 1/2

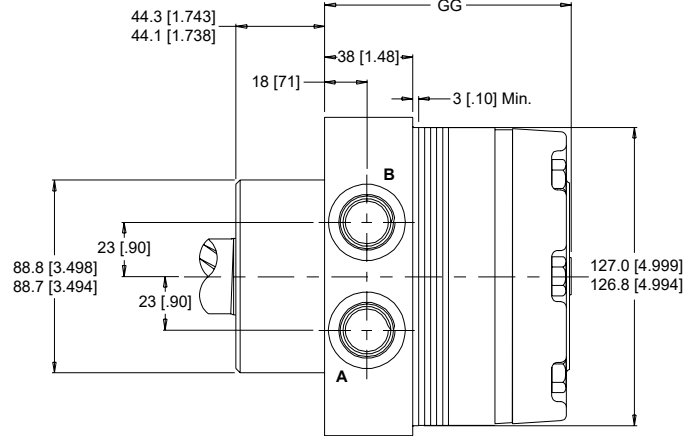
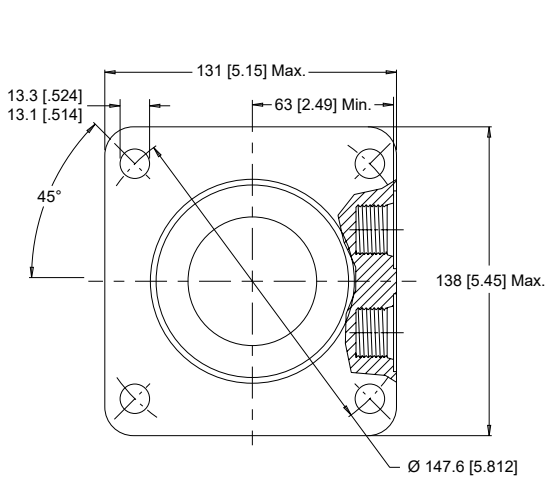

► Dimension GG is charted on page 24.

4-HOLE, WHEEL BRAKE MOUNT, ALIGNED PORTS

K31 7/8-14 UNF **K38** G 1/2

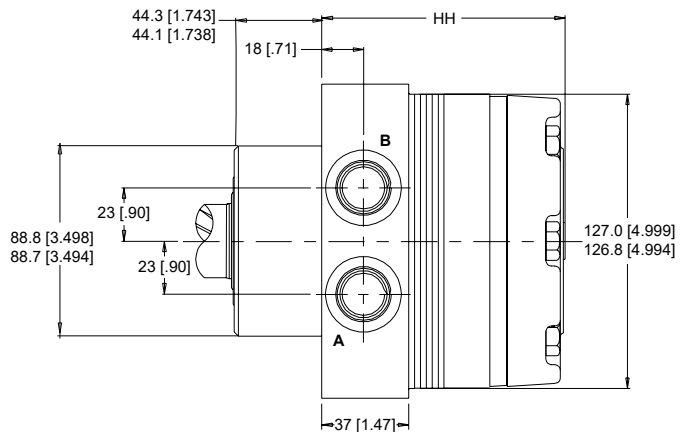
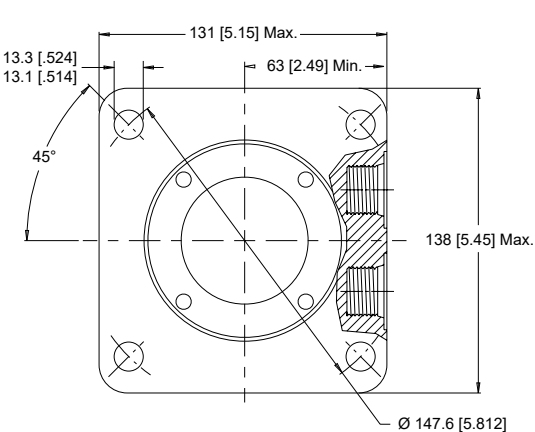

► Dimension HH is charted on page 27.

TECHNICAL INFORMATION

ALLOWABLE SHAFT LOAD / BEARING CURVE

The bearing curve represents allowable bearing loads based on ISO 281 bearing capacity for an L_{10} life of 2,000 hours at 100 rpm. Radial loads for speeds other than 100 rpm may be calculated using the multiplication factor table on page 7.

WHEEL MOUNTS

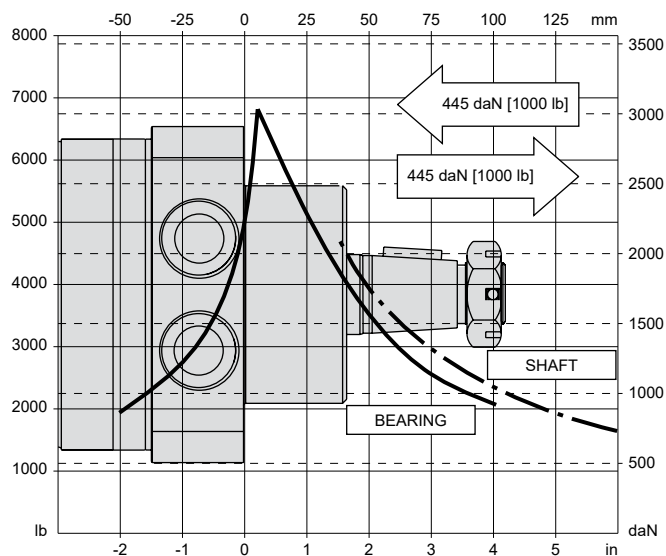

SHAFTS

22 1-1/4" Tapered

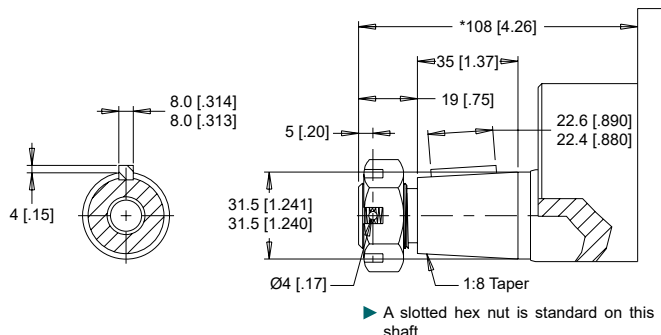

Max. Torque: 1200 Nm [10600 lb-in]

ORDERING INFORMATION

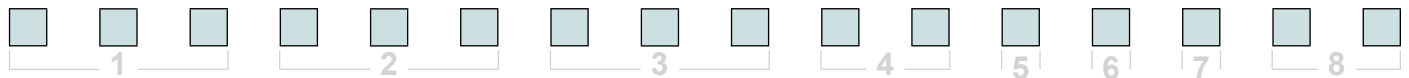

1. CHOOSE SERIES DESIGNATION

- 420** Standard Rotation
- 421** Reverse Rotation

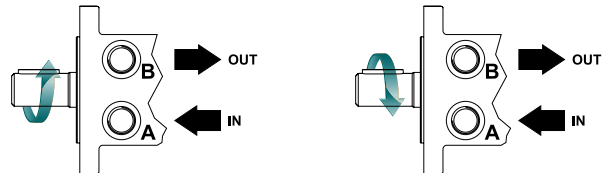

► The 420 & 421 series are bi-directional. For applications requiring the motor to rotate in only one direction, shaft seal life may be prolonged by pressurizing the A port of the motor.

2. SELECT A DISPLACEMENT OPTION

120	121 cm ³ /rev [7.4 in ³ /rev]	350	348 cm ³ /rev [21.2 in ³ /rev]
160	162 cm ³ /rev [9.9 in ³ /rev]	375	375 cm ³ /rev [22.8 in ³ /rev]
200	204 cm ³ /rev [12.4 in ³ /rev]	470	465 cm ³ /rev [28.3 in ³ /rev]
230	232 cm ³ /rev [14.2 in ³ /rev]	540	536 cm ³ /rev [32.7 in ³ /rev]
260	261 cm ³ /rev [15.9 in ³ /rev]	750	748 cm ³ /rev [45.6 in ³ /rev]
300	300 cm ³ /rev [18.3 in ³ /rev]		

3. SELECT A MOUNT & PORT OPTION

P31	4-Hole, 3.25" Pilot Wheel Mount, Aligned Ports, 7/8-14 UNF
P38	4-Hole, 3.25" Pilot Wheel Mount, Aligned Ports, G 1/2
W31	4-Hole, 3.50" Pilot Wheel Mount, Aligned Ports, 7/8-14 UNF
W35	4-Hole, 3.50" Pilot Wheel Mount, Aligned Ports, 9/16-18 UNF
W38	4-Hole, 3.50" Pilot Wheel Mount, Aligned Ports, G 1/2
K31	4-Hole, Wheel Brake Mount, Aligned Ports, 7/8-14 UNF
K38	4-Hole, Wheel Brake Mount, Aligned Ports, G 1/2

► For options not listed in the table above, please contact us with your requirements

4. SELECT A SHAFT OPTION

- 22** 1-1/4" Tapered

5. SELECT A PAINT OPTION

- A** Black
- B** Black, Unpainted Mounting Surface
- Z** No Paint

6. SELECT A VALVE CAVITY / CARTRIDGE OPTION

- A** None

7. SELECT AN ADD-ON OPTION

- A** Standard
- B** Lock Nut
- C** Solid Hex Nut

8. SELECT A MISCELLANEOUS OPTION

- AA** None
- AC** Freeturning Rotor
- AE** Hydraulic Declutch with Freeturning Rotor

HOUSINGS

► Dimensions shown are without paint. Paint thickness can be up to 0.13 [.005].

4-HOLE, WHEEL MOUNT, ALIGNED PORTS

W31 7/8-14 UNF **W38** G 1/2

STANDARD

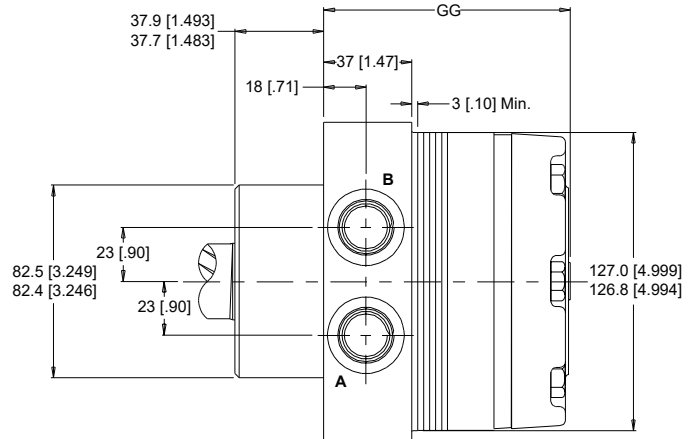
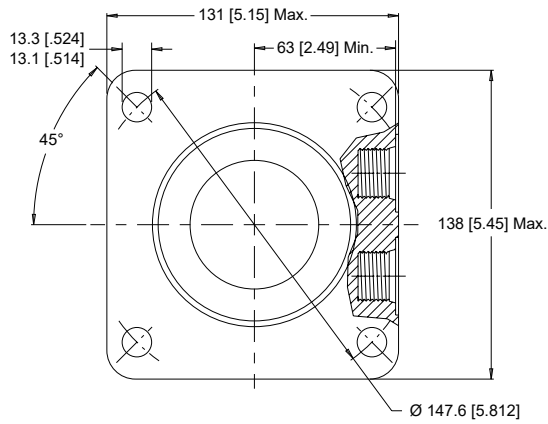

OPTIONAL VALVE CAVITY

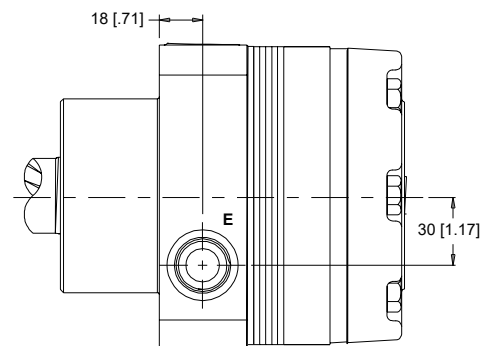
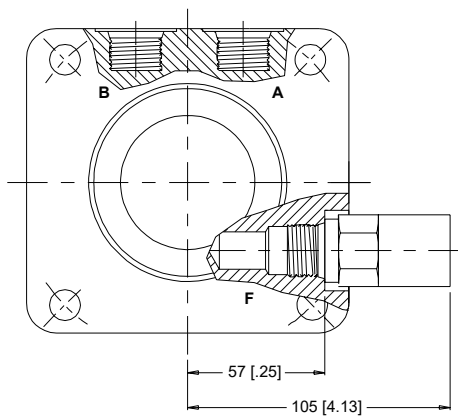

E: 10 Series/2-Way Valve Cavity 7/8-14 UNF F: Valve Cartridge Installed

► Dimension GG is charted on page 24.

TECHNICAL INFORMATION

ALLOWABLE SHAFT LOAD / BEARING CURVE

The bearing curve represents allowable bearing loads based on ISO 281 bearing capacity for an L_{10} life of 2,000 hours at 100 rpm. Radial loads for speeds other than 100 rpm may be calculated using the multiplication factor table on page 7.

WHEEL MOUNTS

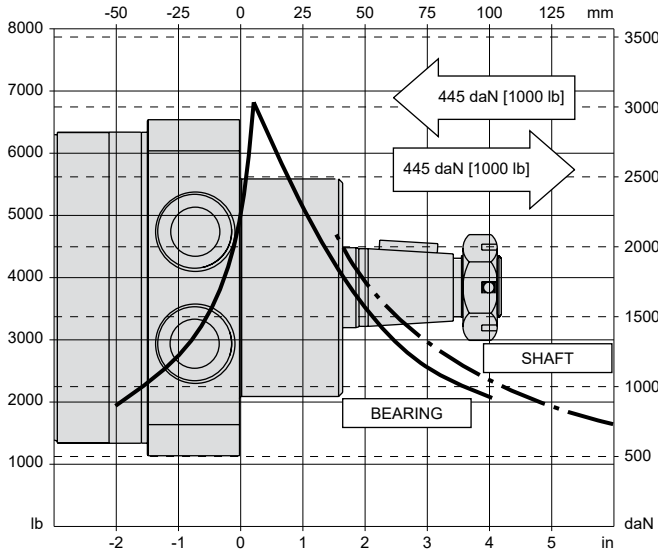

SHAFTS

20 1-1/4" Straight

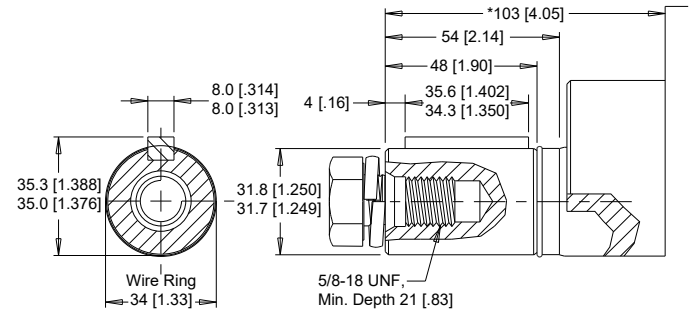

Max. Torque: 1200 Nm [10600 lb-in]

28 35mm Tapered

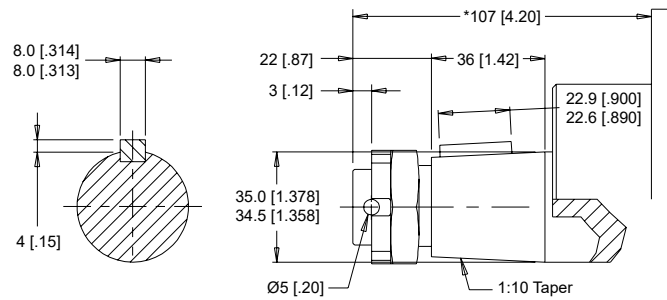

▶ A slotted hex nut is standard on this shaft. Dimensional details & additional options are listed on page 11.

Max. Torque: 1200 Nm [10600 lb-in]

31 1-1/2" Tapered

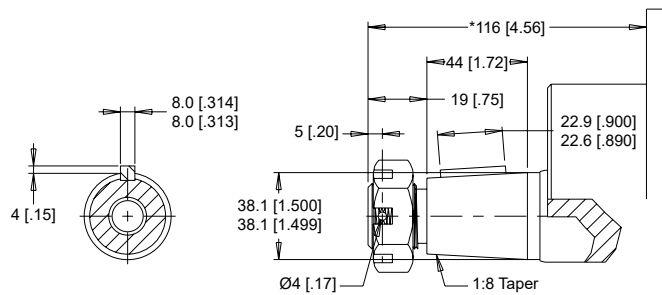

▶ A slotted hex nut is standard on this shaft. Dimensional details & additional options are listed on page 11.

Max. Torque: 1200 Nm [10600 lb-in]

* Mounting flange length may vary by ± .8 [0.030].

ORDERING INFORMATION



1. CHOOSE SERIES DESIGNATION

430 Standard Rotation

431 Reverse Rotation

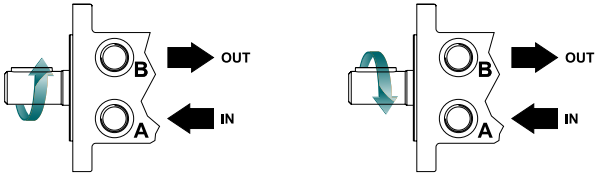

► The 430 & 431 series are bi-directional. For applications requiring the motor to rotate in only one direction, shaft seal life may be prolonged by pressurizing the A port of the motor.

2. SELECT A DISPLACEMENT OPTION

120	121 cm ³ /rev [7.4 in ³ /rev]	350	348 cm ³ /rev [21.2 in ³ /rev]
160	162 cm ³ /rev [9.9 in ³ /rev]	375	375 cm ³ /rev [22.8 in ³ /rev]
200	204 cm ³ /rev [12.4 in ³ /rev]	470	465 cm ³ /rev [28.3 in ³ /rev]
230	232 cm ³ /rev [14.2 in ³ /rev]	540	536 cm ³ /rev [32.7 in ³ /rev]
260	261 cm ³ /rev [15.9 in ³ /rev]	750	748 cm ³ /rev [45.6 in ³ /rev]
300	300 cm ³ /rev [18.3 in ³ /rev]		

3. SELECT A MOUNT & PORT OPTION

W31	4-Hole, Wheel Mount, Aligned Ports, 7/8-14 UNF
W38	4-Hole, Wheel Mount, Aligned Ports, G 1/2

4. SELECT A SHAFT OPTION

20	1-1/4" Straight	28	35mm Tapered
31	1-1/2" Tapered		

5. SELECT A PAINT OPTION

A	Black
B	Black, Unpainted Mounting Surface
Z	No Paint

6. SELECT A VALVE CAVITY / CARTRIDGE OPTION

A	None	E	104 bar [1500 psi] Relief
B	Valve Cavity Only	F	121 bar [1750 psi] Relief
C	69 bar [1000 psi] Relief	G	138 bar [2000 psi] Relief
D	86 bar [1250 psi] Relief		

7. SELECT AN ADD-ON OPTION

A	Standard
B	Lock Nut
C	Solid Hex Nut

8. SELECT A MISCELLANEOUS OPTION

AA	None
AC	Freeturning Rotor
AE	Hydraulic Declutch with Freeturning Rotor

► For options not listed in the table above, please contact us with your requirements

Impro *Fluidtek*

USA

400 E. Diehl Road, Suite 500
Naperville, IL 60563
USA

Email: sales.americas@improfluidtek.com

Luxembourg

10 Boulevard Royal, 2449
Luxembourg

Email: sales.emea@improfluidtek.com

China

No.18, Furong Road 5
Xishan Economy Development Zone
Wuxi, Jiangsu
China

Email: sales.apac@improfluidtek.com
